

Perfect ice, limitless



Catalogue
evo²



INDEX

Company	5
evo ²	11
Strengths	39
Products	43

COMPANY

Young, vibrant, and cutting-edge:
At WM technics, innovation is our top
priority - for both us and our clients.

Established in 1986, WM technics crafts premium **ice resurfacing machines** suitable for every surface and requirement. Our state-of-the-art models stand out with their advanced technology, user-friendly operation, certified safety, and contemporary design.



Ice resurfacing machine **WM 2300**
Year of construction 1986

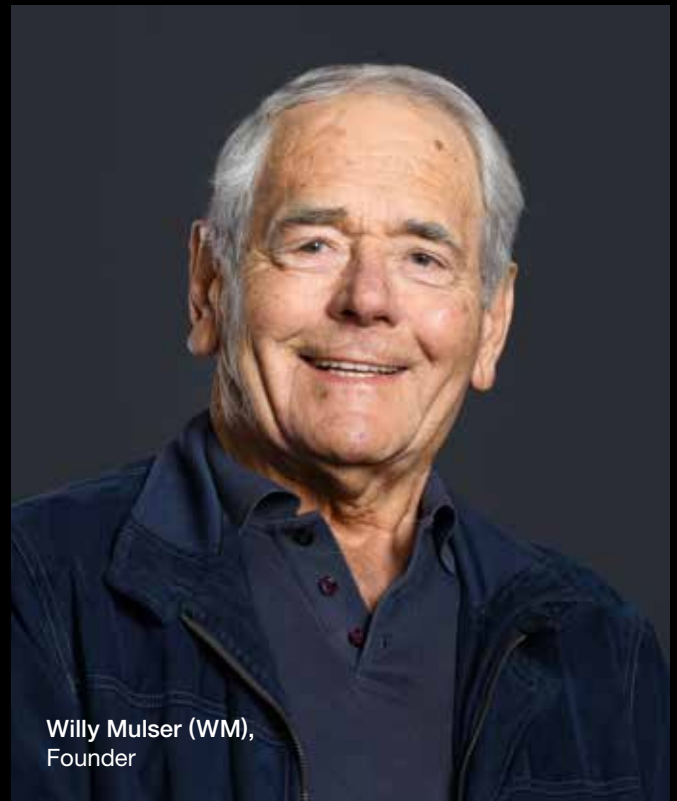

Willy Mulser (WM),
Founder

Here's what we have to offer

Whether catering to professional ice needs within an arena or on a mobile rink, the distinction is minimal: WM technics consistently offers the optimal solution for any requirement. Owing to our relentless pursuit of product excellence, we pioneer cutting-edge standards and stand as a prominent leader in the worldwide market.

Powered by our robust digital infrastructure; design, parts production, and

the assembly of ice resurfacing machines are conducted at our South Tyrol-based facility (Italy).

In this manner, WM technics guarantees unparalleled quality, attending to every intricate detail. Custom setups built on customer specifications, reduced maintenance commitment, and steadfast assistance affirm WM technics as a powerful ally.

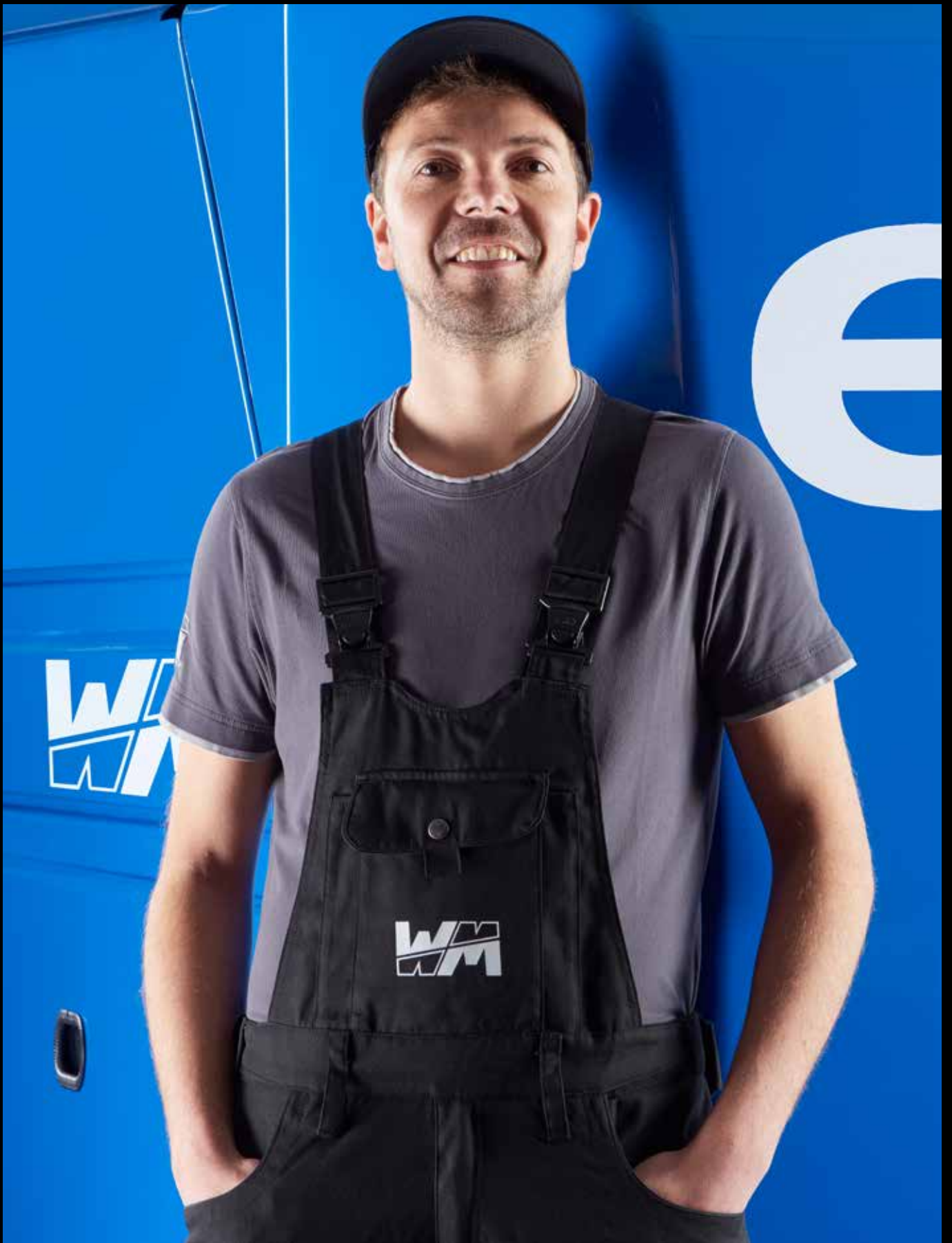

Lukas,
Assembly Team

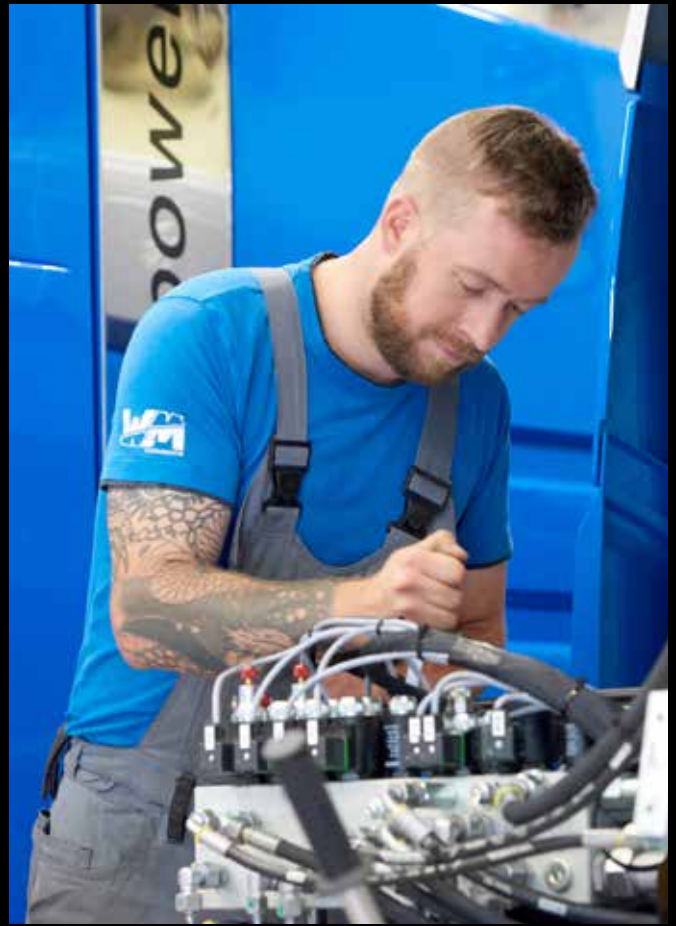



Always Ahead of the Curve

With precision, we delve into research, trials, and systems. Our team's years of prowess in development, manufacturing, and setup culminate into a harmonious synergy.



Safety at its Finest

Our cardinal rule: Prioritizing safety and well-being. WM technics' ice machines are designed with intuitiveness and uncompromised safety, meeting European machinery guidelines.



Design with a Spark

WM technics brings to life trailblazing ice machines, always keeping the client and entire production lifecycle at heart.



Precision Production

WM technics manufactures all its turning and milling components with utmost precision in its production department, only sourcing standard parts from reputable manufacturers. Each component is then customized in detail based on its function and crafted with the greatest care.



Streamlined Assembly

WM technics champions the rapid production of ice machines, backed by rigorously organized processes. Every move is intricately mapped and transparent. Our commitment to precision minimizes the need for maintenance.



360-Degree Quality

WM technics designs and produces innovative ice resurfacing machines that meet all efficiency, reliability, longevity, and ease-of-use requirements. Series construction and in-house production also allow for the detailed tracking of all fabrication stages and utilized components.



Sustainability with Vision

WM technics machines are designed to stand the test of time. We advocate for enduring products while keeping an eye on operational expenses. Balancing energy conservation, reduced consumption, and profitability doesn't deter us from delivering peak performance.



Customer-Centric Assistance

Just as our machines care for the ice, we cherish our relationships with our customers: not only before the purchase but also during the commissioning and afterwards. We meet our clients' unique requirements even during the production process, tailoring our approach to their needs.

evo²

LITHIUM
DIESEL
PETROL / GASOLINE





evo²

The ideal ice resurfacer for larger areas,
designed for high performance, flexibility
of use and simplified maintenance.

The powerhouse in ice resurfacing for heavy-duty use on ice rinks and stadiums of over **4,200 m² / 45,200 ft²**.

The powerful evo² can handle any task on ice rinks or in stadiums with ease. Its large-volume, combinable snow and water tanks allow for flexible use, with power provided by diesel, petrol or electric motors.

The ultra-fast blade replacement system, excellent overview of controls and automatic mode all ensure outstanding user-friendliness. Rapid access to the engine compartment makes maintenance quick and inexpensive.

	Snow tank volume	4.1 m ³ / compacted 5.1 m ³ 145 ft ³ / compacted 180 ft ³
	Water tank volume	1,200 l / 1,400 l / 2,000 l 317 gal / 370 gal / 528 gal + snow tank-water tank connection 2,550 l / 2,750 l 674 gal / 726 gal
	Blade width	2,300 mm / 2,500 mm 90 1/2 in / 98 1/2 in Blade change < 60 seconds
	Field of operation	Pro / Ice stadiums

“Our arena is a training centre for international teams and a venue for major sporting events. Perfect ice quality is an absolute must! With the evo² I can guarantee perfect ice rinks.”

Toni Doppler - Ice Master
Max Aicher Arena
(Germany)





Safety and protective features

At WM technics, safety and health protection always come first. A thorough and independent inspection carried out by [Suva](#), the accredited and recognized Swiss certification body, confirms compliance with the European Directive 2006/42/EC, which regulates the level of protection against machinery-related accidents to ensure user safety.

suva
CERTIFICATION

In compliance with Suva certification No. E 7139/2.e

Highlight

Driver's Cabin

evo² offers maximum driver **comfort**. The cabin provides all-round vision at all times. There is a step for ease of access.

All important information is clearly visible at a glance on the high-definition colour display, and all main functions are keyboard-controlled. At a simple press of a button, the automatic mode begins all work operations in a pre-defined order, while the height-adjustable Grammer suspension seat provides outstanding comfort.



Exclusive comfort

Panoramic view

Maximum control

Highlight

Ultra-light Blade

The evo² quick blade-change system eases working life enormously: blades can be changed in just **60 seconds!**

The blades are made of a special steel, giving both an above-average service life and an impressive weight of just 3.5 kilos / 7.7 lbs. Blades can therefore be changed quickly and safely.



⚖️ 3.5 kg / 7.7 lbs

Two blades together with all accessory equipment are supplied as standard in a practical wooden transport box.



Easy, quick and precise

Low injury risk

Superior quality of ice

Highlight

Integrated Edger

The edger is fixed to the body of the evo²,
guaranteeing **outstanding stability** and **performance**.

The edger can be operated easily and safely from the driver's seat. The innovative horizontal suspension system with guide wheel ensures that the edger perfectly follows the contours of the rink to a constant planing depth, while excess ice is efficiently and cleanly removed.

The swivel brushes permit the edging and subsequent cleaning of the ice surface in one simple step. The edgers are positioned between the axles and in front of the brush, ensuring an unrestricted overview of the vehicle. When not in use, the edgers are stored between the wheels and do not affect operation in any way.



Perfect adaptation to edges

Planing and cleaning

Horizontal suspension system

Highlight

Snow tank- Water tank

More water is a must when building up ice depth or using a water fountain: the evo² has it all taken care of!

The water and snow tanks can easily be connected into one water tank with a total volume of around 2,550 litres / 674 gal.

No more standing in cold water or tyre some tugging on hoses: all operations can be carried out from the comfort of the driver's cabin – there's more than enough water to do the job.

Example:

large water tank 1,400-litre / 370 gal
+ 1,350-litre / 356 gal snow tank
= 2,750 litres / 726 gal of water

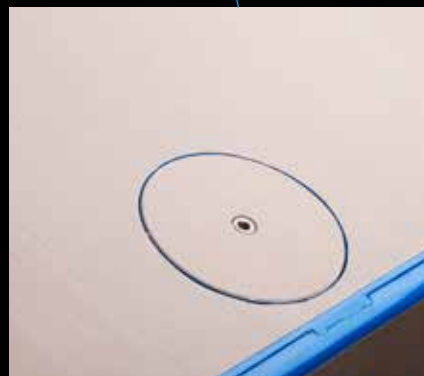

Cover closed



Cover open: connected

Optimised capacity

Continuous smooth operation

Greater comfort

Highlight

LiFePO₄ Lithium battery

LiFePO4 batteries deliver **robust performance while being eco-friendly**, lacking harmful heavy metals and being mostly recyclable. Installed in evo², they stand as an eco-optimized solution meeting top-tier demands.

Performance

The lithium iron phosphate battery not only ensures extended longevity but also provides a consistent and reliable power supply.

Sustainability

LiFePO4 batteries are free from toxic heavy metals and are almost 100% recyclable, with a lifespan of 3-4 times as many charging cycles as lead acid batteries.

Center of gravity

Our centrally and deeply positioned battery not only ensures maximum stability but also optimizes the overall balance of the machine.

In-house Assembly

Battery packs are specifically tailored to machine requirements and are assembled in-house, ensuring quality and adaptability.



Highlight

Maintenance

Easy maintenance and **low operating costs** with evo²: simply lift the cabin to access all components in the engine compartment.

This means that our mechanics can carry out their work quickly and cleanly, which in turn saves on time and service costs. Our team can also use remote monitoring to keep an eye on your vehicle and rectify any faults which may occur.

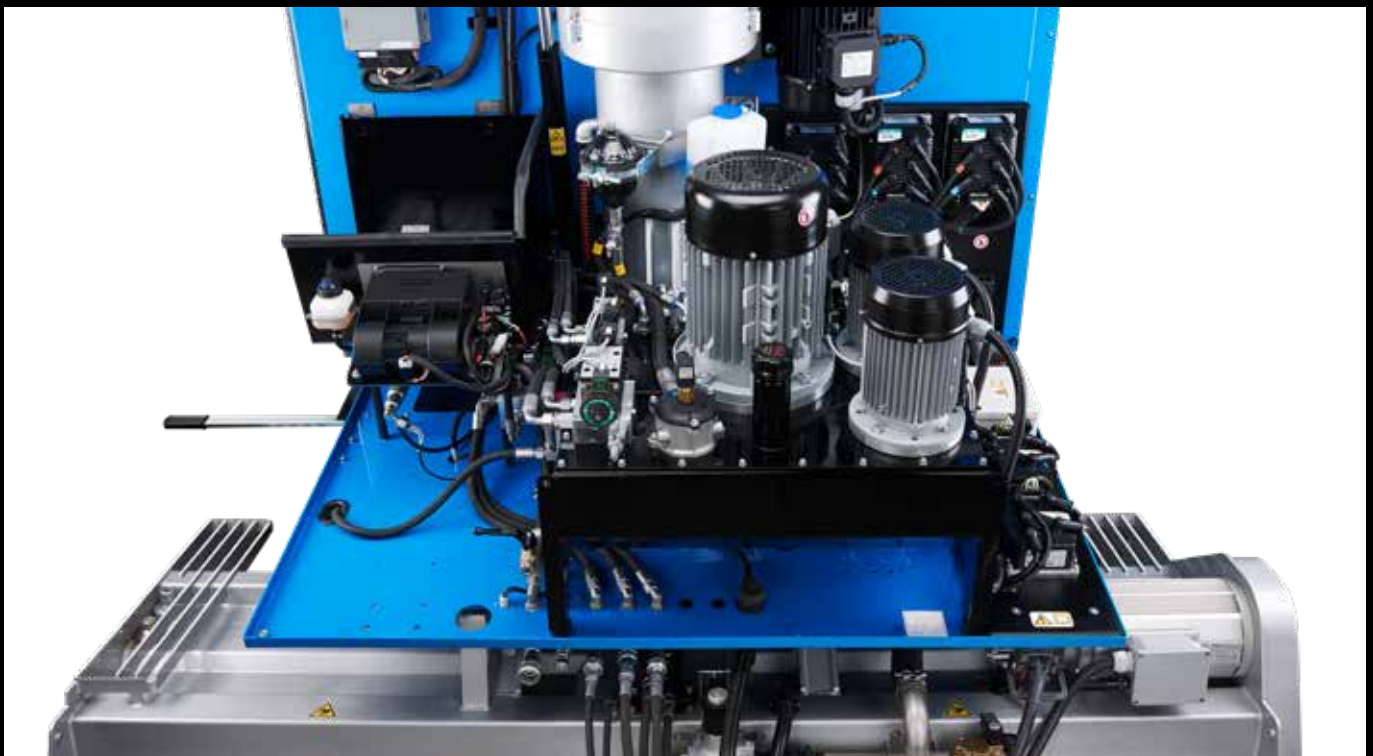

Cost-effective maintenance and operation

Free and rapid access to the engine compartment

Skilled remote maintenance

TECHNOLOGY

Its technology means the evo² can resurface large ice surfaces to a very high standard, guaranteeing a perfect finish for even the biggest areas.



Its innovative technology offers unprecedented benefits: the precision of its mechanics and control systems ensure uniform resurfacing with perfectly smooth ice.

Designed for maximum efficiency, evo² minimises consumption, optimises performance and reduces running costs.

evo² is designed to meet every need and thus offers three different drive options: Lithium, Diesel and Petrol / Gasoline.

The cabin can be hydraulically lifted for quick and easy access to the engine compartment, which greatly facilitates maintenance tasks.

Technical specifications

Motor	7 asynchronous motors
Total power	35 kW
Water tank	1,200 l 317 gal / Optional 1,400 l 370 gal / 2,000 l 528 gal
Snow tank	4.1 m ³ / compacted 5.1 m ³ 145 ft ³ / compacted 180 ft ³
Transmission	Continuously adjustable electric all-wheel drive
Hydraulic oil tank	50 l 13 gal
Speed	0 - 13 km/h 0 - 8 mph
Tyres	225 / 75 / R16 C 6 rows of spikes
Wheel rims	8" x 16"



Standard equipment

Cab with heated windshield in safety glass, windscreen wiper system and interior light
PLC control
7 inch colour display
USB port for installing updates and data exchange
Button for automatic mode: Operations start automatically in a predefined order
Spring-suspended and height-adjustable driver's seat (fabric)
Armrest with storage capacity
Power steering
Easily-accessible engine compartment (tiltable) with cab support
Maintenance-free asynchronous motors
Water tank made of PE
Snow bin & water tank connection (> 2,550 litres / 674 gal)
Function for automatic water filling system with immobilizer
Coated snow tank
Footbrake and parking brake
Hydraulically driven and swivelling side brush
Board guide pulley
Rear mirror
Front headlights, snow bin headlight, side headlight
Flashing warning light
Acoustic signal for reverse drive, snow bin cover operation, reverse of the screw conveyors and blade exchange
Proportional water metering
System for water dosing in curves
Conditioner made of stainless steel
Constant grinding pressure conditioner
Quick-Change-System for fast blade replacement (< 60 seconds)
2 blades in wooden transport box (super-light blade - 3.5 kg / 7.7 lbs)
2 towels
Scope of delivery-set



In compliance with Suva certification No. E 7139/2.e

Diesel

Technical specifications

Engine	Hatz 4H50TICD, 4 cylinder 1,952 cm ³ 119 in ³
Power	55.4 kW / 74.3 HP - 2,800 rpm
Torque	240 Nm - 1,600 rpm
Exhaust gas treatment	DOC, DPF with EGR Emission Stage V / EPA Tier 4 final
Unloaded weight	3,750 kg (basic outfit) 8,267 lbs
Water tank	1,450 l 383 gal / Optional 1,600 l 423 gal / 2,200 l 581 gal
Snow tank	4.1 m ³ / compacted 5.1 m ³ 145 ft ³ / compacted 180 ft ³
Transmission	Continuously adjustable hydraulic all-wheel drive
Fuel tank	52 l 14 gal
Hydraulic oil tank	65 l 17 gal
Speed	0 - 16 km/h 0 - 10 mph
Tyres	225 / 75 / R16 C 6 rows of spikes
Wheel rims	8" x 16"



Standard equipment

Cab with heated windshield in safety glass, windscreen wiper system and interior light
PLC control
7 inch colour display
USB port for installing updates and data exchange
Button for automatic mode: Operations start automatically in a predefined order
Spring-suspended and height-adjustable driver's seat (fabric)
Armrest with storage capacity
Power steering
Easily-accessible engine compartment (tiltable) with cab support
Hydraulic oil cooler
Water and fuel tank made of PE
Function for automatic water filling system with immobilizer
Coated snow tank
Snow bin & water tank connection (> 2,750 l / 726 gal)
Footbrake and parking brake
Hydraulically driven and swivelling side brush
Board guide pulley
Rear mirror
Front headlights, snow bin headlight, side headlight
Flashing warning light
Acoustic signal for reverse drive, snow bin cover operation, reverse of the screw conveyors and blade exchange
Proportional water metering
System for water dosing in curves
Conditioner made of stainless steel
Constant grinding pressure conditioner
Quick-Change-System for fast blade replacement (< 60 seconds)
2 blades in wooden transport box (super-light blade - 3.5 kg / 7.7 lbs)
2 towels
Scope of delivery-set



In compliance with Suva certification No. E 7139/2.e

Petrol / Gasoline

Technical specifications

Engine	Ford MSG 425, 2,500 cm ³ 152 in ³
Power	51.5 kW / 70 HP - 2,600 rpm
Torque	190 Nm - 2,600 rpm
Unloaded weight	3,750 kg (basic outfit) 8,267 lbs
Water tank	1,450 l 383 gal / Optional 1,600 l 423 gal / 2,200 l 581 gal
Snow tank	4.1 m ³ / compacted 5.1 m ³ 145 ft ³ / compacted 180 ft ³
Transmission	Continuously adjustable hydraulic all-wheel drive
Fuel tank	52 l 14 gal
Hydraulic oil tank	65 l 17 gal
Speed	0 - 13 km/h 0 - 8 mph
Tyres	225 / 75 / R16 C 6 rows of spikes
Wheel rims	8" x 16"



Standard equipment

Cab with heated windshield in safety glass, windscreen wiper system and interior light
PLC control
7 inch colour display
USB port for installing updates and data exchange
Button for automatic mode: Operations start automatically in a predefined order
Spring-suspended and height-adjustable driver's seat (fabric)
Armrest with storage capacity
Power steering
Easily-accessible engine compartment (tiltable) with cab support
Hydraulic oil cooler
Water and fuel tank made of PE
Function for automatic water filling system with immobilizer
Coated snow tank
Snow bin & water tank connection (> 2,750 l / 726 gal)
Footbrake and parking brake
Hydraulically driven and swivelling side brush
Board guide pulley
Rear mirror
Front headlights, snow bin headlight, side headlight
Flashing warning light
Acoustic signal for reverse drive, snow bin cover operation, reverse of the screw conveyors and blade exchange
Proportional water metering
System for water dosing in curves
Conditioner made of stainless steel
Constant grinding pressure conditioner
Quick-Change-System for fast blade replacement (< 60 seconds)
2 blades in wooden transport box (super-light blade - 3.5 kg / 7.7 lbs)
2 towels
Scope of delivery-set



In compliance with Suva certification No. E 7139/2.e

Dimensions

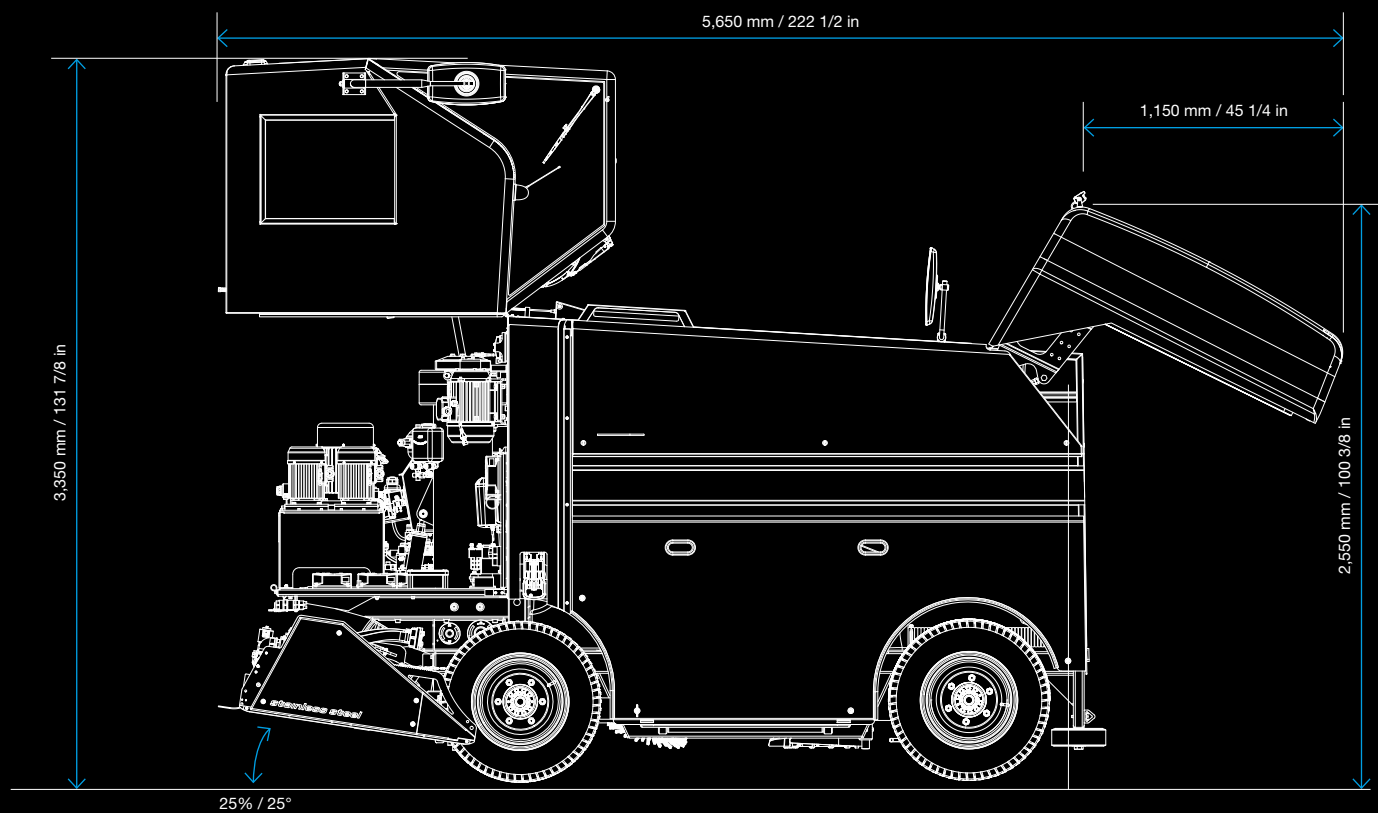
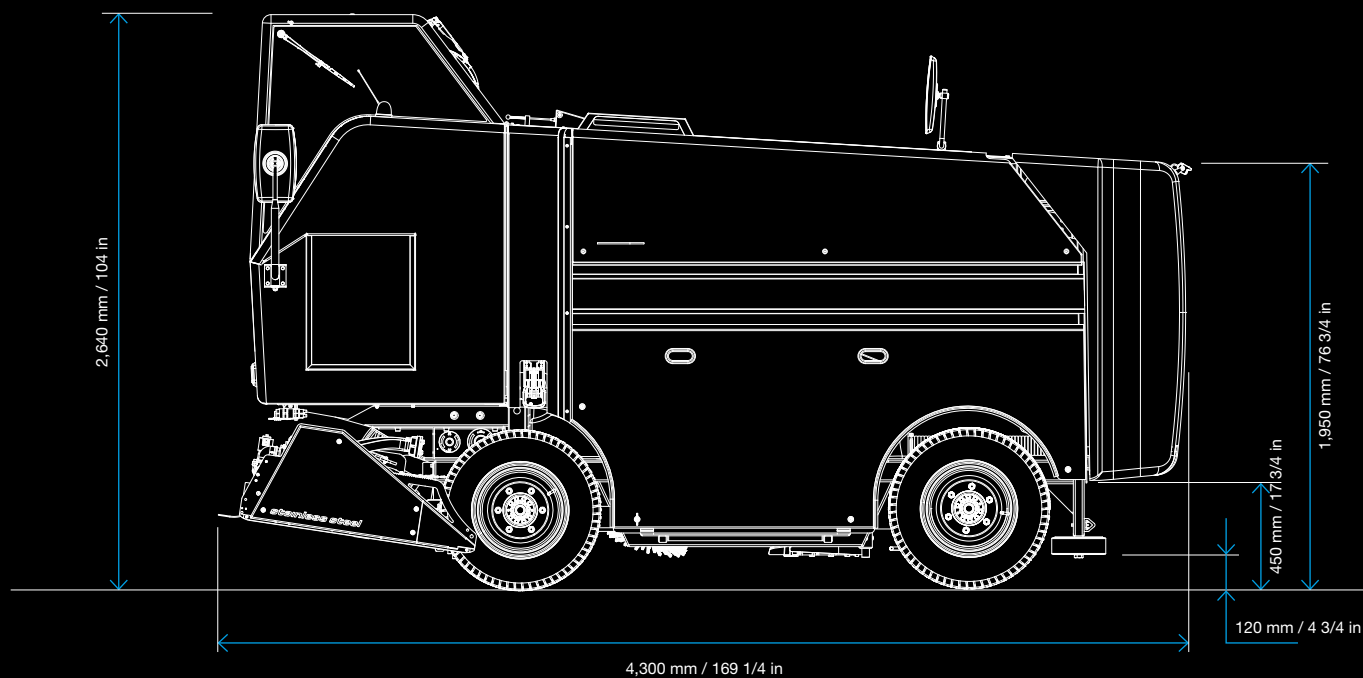

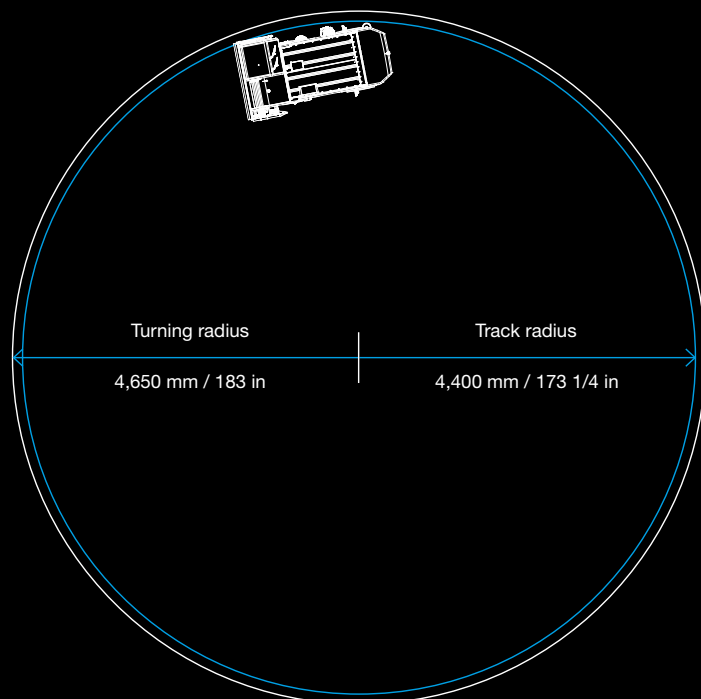
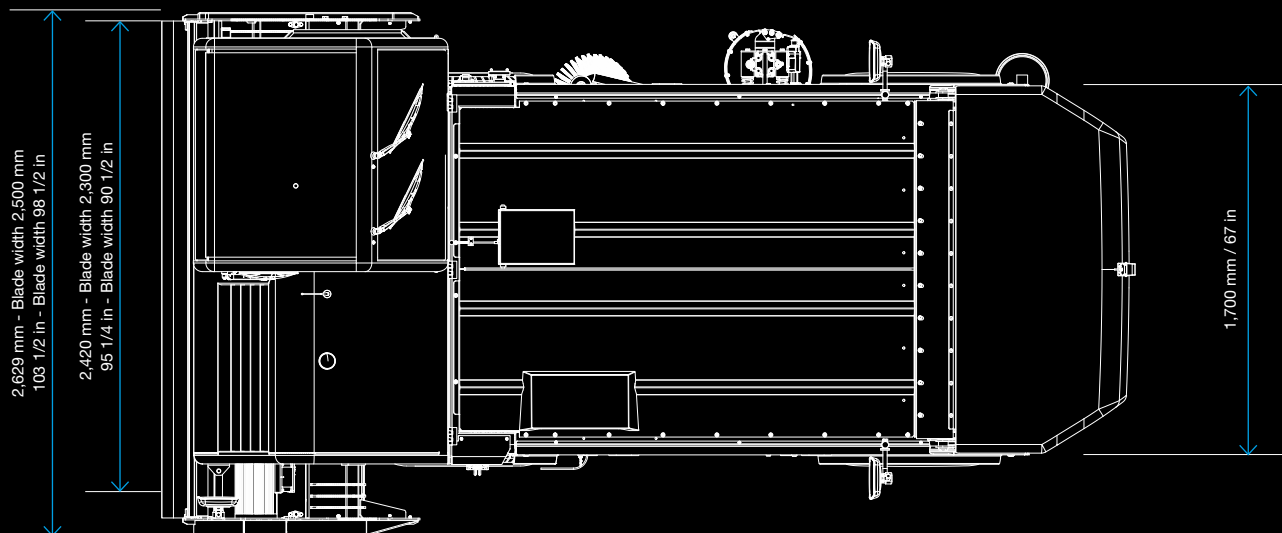

Optional



Wash system



Ice wash system
Multijet
with suction ledge



Screw conveyor
wash system
vertical
*can be activated during
ice resurfacing*



Screw conveyor
wash system
horizontal
*can be activated during
ice resurfacing*



Snow bin
wash system



Wheel wash
system
co-steering

Dasher board processing



Edger
*Stainless steel, spring-mounted
and electric height adjustment*

Water application



Towel support
standard



Towel lifter
automatic



ICEplus
Water spraying system



ICEplus Flexi
*Water spraying system
with automatic towel lifter*



Water fountain

Overview and security



Side mirror
front left



Side mirror
front right

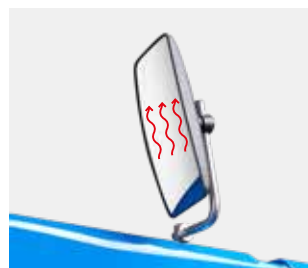

Heated mirrors



Front camera
Rear-view camera

Comfort



Cab heating



Driver's seat heating



Joystick



Radio



Acquastop valve



LED headlights



Tail lights



RGB underbody illumination

Personalization



Painting



Wrapping



Without cabin

Service



Battery trolley



Spare tyre 16"



Cross-key



Lifting jack



Assembly tool for nozzles ICEplus



Kit diagnostic cables

Bavarian Curling



Groove harrow

Spare parts



Blade

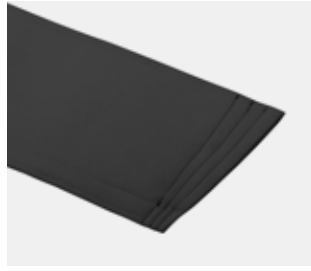

Towel felt



Towel terry



Edger blades

STRENGTHS

WM technics - Excellence in design and quality. In-house manufactured machines. Easy maintenance. Quick access to spare parts. Your guarantee for the highest standards.

At WM technics, we strive for excellence at every stage of our work. Our machines are the result of high-quality components and meticulous design that minimizes maintenance effort. Designed, manufactured, and assembled in our own facilities, we guarantee top quality and timely deliveries. From component to the finished product - every step is closely monitored to deliver to you **the ice resurfacing machines of the future.**

User friendliness



Through the use of top-quality components together with a well-planned design, maintenance work is extremely simple and is reduced to a minimum.

Quality guarantee



Our products are developed, manufactured, and assembled in-house at our facilities. This is the only way we can guarantee the best quality and punctual delivery times.

The right replacement part, every time



Order your spare parts easily and conveniently from our online portal: Our series number and digital image system enable you to find the part you need with just one click.

Series production



All WM technics vehicles are series-manufactured. We know exactly which parts have been used in each series run, and can deliver the correct spare parts to you at all times. At the same time, a number of optionals can be retrofitted with minimum effort and maximum precision, even years later.

Service and support



Our well-networked, international team of technicians undergo constant training and will be delighted to help you whenever you require assistance.

Quality consciousness



From the manufacture of individual parts right through to the final quality-control inspection: Every step of the process is carried out and monitored with the utmost precision. Each and every member of our staff is well-trained in his specialist field, and carries out all tasks conscientiously. This is a great advantage for our customers, who can be sure of receiving a technologically sophisticated product which has been manufactured to the very highest quality standards.

PRODUCTS

Dive into the world of WM technics: Where cutting-edge design meets top-notch quality. Here begins the journey to top-tier ice resurfacing machines and #perfectice.





Mammoth

An autonomous and innovative ice resurfacing machine, ideal for stadiums and large ice surfaces up to 2,600 m² / 28,000 ft².

Maintenance-free AC motors, generous tank volumes, and the quick-change blade system ensure fast and efficient ice preparation. The compact design and frame-mounted edger provide maximum stability and exceptional maneuverability.

Mammoth
also available with
Autopilot 3D







 Snow tank volume	3 m ³ / compacted 3.6 m ³ 106 ft ³ / compacted 127 ft ³
 Water tank volume	1,000 l / 1,350 l / 1,750 l 264 gal / 356 gal / 462 gal + snow tank-water tank connection 2,000 l / 2,350 l / 2,750 l 528 gal / 620 gal / 726 gal
 Blade width	2,100 mm / 2,300 mm / 2,500 mm 82 5/8 in / 90 1/2 in / 98 1/2 in Blade change < 60 seconds
 Fields of operation	Pro / Ice stadiums

Shira

The machine adapts perfectly to every ice resurfacing requirement in stadiums with ice surfaces up to 2,600 m² / 28,000 ft².

It runs electrically and operates almost silently. The intuitive control via keyboard, display, and automatic mode enables particularly easy operation and maintenance. Thanks to excellent accessibility for manual interventions, it ensures noticeable cost savings and impresses with an outstanding price-performance ratio.



 Snow tank volume	3 m ³ / compacted 3.6 m ³ 106 ft ³ / compacted 127 ft ³
 Water tank volume	1,000 l / 1,350 l / 1,750 l 264 gal / 356 gal / 462 gal + snow tank-water tank connection 2,000 l / 2,350 l / 2,750 l 528 gal / 620 gal / 726 gal
 Blade width	2,100 mm / 2,300 mm 82 5/8 in / 90 1/2 in
 Fields of operation	Pro / Ice stadiums





evo²

The powerful ice resurfacing machine for intensive operations on large ice rinks and in stadiums – ideal for ice surfaces from 4,200 m² / 45,200 ft².

The generously combinable snow and water tank volume offers maximum flexibility, while diesel, gasoline, or electric motors provide the drive as needed.

The very fast blade change system, excellent overview of all operating functions, and automatic mode significantly facilitate handling. Thanks to quick access to the engine compartment, maintenance is also particularly fast and cost-efficient.







 Snow tank volume	4.1 m ³ / compacted 5.1 m ³ 145 ft ³ / compacted 180 ft ³
 Water tank volume	1,200 l / 1,400 l / 2,000 l 317 gal / 370 gal / 528 gal + snow tank-water tank connection 2,550 l / 2,750 l 674 gal / 726 gal
 Blade width	2,300 mm / 2,500 mm 90 1/2 in / 98 1/2 in Blade change < 60 seconds
 Fields of operation	Pro / Ice stadiums

Compact

The compact ice resurfacing machine was specifically designed for small ice surfaces and rinks up to 1,200 m² / 12,900 ft².

It is robust, easy to operate, and delivers shaving results like a large professional model. Thanks to its high maneuverability, it offers the driver first-class comfort and guarantees professional ice preparation – even on mobile ice rinks, it ensures ice quality at the highest level.







 Snow tank volume	1.8 m ³ / compacted 2.25 m ³ 63.6 ft ³ / compacted 79.5 ft ³
 Water tank volume	600 l 158 gal
 Blade width	1,700 mm 66 7/8 in
 Fields of operation	Event / Small ice rinks

Pinguino

The compact revolution among ice resurfacing machines: Thanks to its small dimensions, it moves with extreme agility and delivers precise, high-quality ice preparation for events and mobile ice rinks up to 800 m² / 8,600 ft².

It offers the performance of large professional machines – shaves the ice efficiently and ensures perfect ice quality at all times. The unique forward seating position provides the driver with excellent visibility and high driving comfort.





	Snow tank volume	1 m ³ / compacted 1.25 m ³ 35.3 ft ³ / compacted 44.2 ft ³
	Water tank volume	340 l 90 gal
	Blade width	1,400 mm 55 1/8 in
	Fields of operation	Event / Small ice rinks

Snip

The electrically operated, manually guided edger makes ice maintenance considerably easier.

Whether mobile ice rinks or large arenas – it combines a compact design with modern, emission-free technology. Its most innovative feature is the quick, tool-free switching between two operating modes: lateral milling along the boards and frontal milling to remove ice build-up and unevenness. With an integrated drive, adjustable speed, and certified safety, it is a versatile and precise tool for maintaining any ice surface.



	Electric engine	24V / 130Ah (powered by a FAAM TRALEG battery)
	Blade width	Ø 350 mm Ø 13.8 in
	Fields of operation	Event / Ice stadiums



evo²

Inzell
www.inzell.de

WM technics GmbH

Plant 1, Headquarters
Breiener Straße 15
I-39053 Blumau
T. +39 0471 353 332
info@wm-technics.com
wm-technics.com

Plant 2
Giuseppe-di-Vittorio-Straße 18
I-39100 Bozen

Follow us on

YouTube: *WM ice*
Facebook: *WM ice*
Instagram: *WM ice*
LinkedIn: *WM technics*

