

Perfect ice, limitless







Product sheet
evo²



The powerhouse in ice resurfacing for heavy-duty use on ice rinks and stadiums of over **4,200 m² / 45,200 ft²**.

The powerful evo² can handle any task on ice rinks or in stadiums with ease. Its large-volume, combinable snow and water tanks allow for flexible use, with power provided by diesel, petrol or electric motors.

The ultra-fast blade replacement system, excellent overview of controls and automatic mode all ensure outstanding user-friendliness. Rapid access to the engine compartment makes maintenance quick and inexpensive.

	Snow tank volume	4.1 m ³ / compacted 5.1 m ³ 145 ft ³ / compacted 180 ft ³
	Water tank volume	1,200 l / 1,400 l / 2,000 l 317 gal / 370 gal / 528 gal + snow tank-water tank connection 2,550 l / 2,750 l 674 gal / 726 gal
	Blade width	2,300 mm / 2,500 mm 90 1/2 in / 98 1/2 in Blade change < 60 seconds
	Field of operation	Pro / Ice stadiums

“Our arena is a training centre for international teams and a venue for major sporting events. Perfect ice quality is an absolute must! With the evo² I can guarantee perfect ice rinks.”

Toni Doppler - Ice Master
Max Aicher Arena
(Germany)





Safety and protective features

At WM technics, safety and health protection always come first. A thorough and independent inspection carried out by [Suva](#), the accredited and recognized Swiss certification body, confirms compliance with the European Directive 2006/42/EC, which regulates the level of protection against machinery-related accidents to ensure user safety.

suva
CERTIFICATION

In compliance with Suva certification No. E 7139/2.e

TECHNOLOGY

Its technology means the evo² can resurface large ice surfaces to a very high standard, guaranteeing a perfect finish for even the biggest areas.



Its innovative technology offers unprecedented benefits: the precision of its mechanics and control systems ensure uniform resurfacing with perfectly smooth ice.

Designed for maximum efficiency, evo² minimises consumption, optimises performance and reduces running costs.

evo² is designed to meet every need and thus offers three different drive options: Lithium, Diesel and Petrol / Gasoline.

The cabin can be hydraulically lifted for quick and easy access to the engine compartment, which greatly facilitates maintenance tasks.

Technical specifications

Motor	7 asynchronous motors
Total power	35 kW
Water tank	1,200 l 317 gal / Optional 1,400 l 370 gal / 2,000 l 528 gal
Snow tank	4.1 m ³ / compacted 5.1 m ³ 145 ft ³ / compacted 180 ft ³
Transmission	Continuously adjustable electric all-wheel drive
Hydraulic oil tank	50 l 13 gal
Speed	0 - 13 km/h 0 - 8 mph
Tyres	225 / 75 / R16 C 6 rows of spikes
Wheel rims	8" x 16"



Standard equipment

Cab with heated windshield in safety glass, windscreen wiper system and interior light
PLC control
7 inch colour display
USB port for installing updates and data exchange
Button for automatic mode: Operations start automatically in a predefined order
Spring-suspended and height-adjustable driver's seat (fabric)
Armrest with storage capacity
Power steering
Easily-accessible engine compartment (tiltable) with cab support
Maintenance-free asynchronous motors
Water tank made of PE
Snow bin & water tank connection (> 2,550 litres / 674 gal)
Function for automatic water filling system with immobilizer
Coated snow tank
Footbrake and parking brake
Hydraulically driven and swivelling side brush
Board guide pulley
Rear mirror
Front headlights, snow bin headlight, side headlight
Flashing warning light
Acoustic signal for reverse drive, snow bin cover operation, reverse of the screw conveyors and blade exchange
Proportional water metering
System for water dosing in curves
Conditioner made of stainless steel
Constant grinding pressure conditioner
Quick-Change-System for fast blade replacement (< 60 seconds)
2 blades in wooden transport box (super-light blade - 3.5 kg / 7.7 lbs)
2 towels
Scope of delivery-set



In compliance with Suva certification No. E 7139/2.e

Diesel

Technical specifications

Engine	Hatz 4H50TICD, 4 cylinder 1,952 cm ³ 119 in
Power	55.4 kW / 74.3 HP - 2,800 rpm
Torque	240 Nm - 1,600 rpm
Exhaust gas treatment	DOC, DPF with EGR Emission Stage V / EPA Tier 4 final
Unloaded weight	3,750 kg (basic outfit) 8,267 lbs
Water tank	1,450 l 383 gal / Optional 1,600 l 423 gal / 2,200 l 581 gal
Snow tank	4.1 m ³ / compacted 5.1 m ³ 145 ft ³ / compacted 180 ft ³
Transmission	Continuously adjustable hydraulic all-wheel drive
Fuel tank	52 l 14 gal
Hydraulic oil tank	65 l 17 gal
Speed	0 - 16 km/h 0 - 10 mph
Tyres	225 / 75 / R16 C 6 rows of spikes
Wheel rims	8" x 16"



Standard equipment

Cab with heated windshield in safety glass, windscreen wiper system and interior light
PLC control
7 inch colour display
USB port for installing updates and data exchange
Button for automatic mode: Operations start automatically in a predefined order
Spring-suspended and height-adjustable driver's seat (fabric)
Armrest with storage capacity
Power steering
Easily-accessible engine compartment (tiltable) with cab support
Hydraulic oil cooler
Water and fuel tank made of PE
Function for automatic water filling system with immobilizer
Coated snow tank
Snow bin & water tank connection (> 2,750 l / 726 gal)
Footbrake and parking brake
Hydraulically driven and swivelling side brush
Board guide pulley
Rear mirror
Front headlights, snow bin headlight, side headlight
Flashing warning light
Acoustic signal for reverse drive, snow bin cover operation, reverse of the screw conveyors and blade exchange
Proportional water metering
System for water dosing in curves
Conditioner made of stainless steel
Constant grinding pressure conditioner
Quick-Change-System for fast blade replacement (< 60 seconds)
2 blades in wooden transport box (super-light blade - 3.5 kg / 7.7 lbs)
2 towels
Scope of delivery-set



In compliance with Suva certification No. E 7139/2.e

Petrol / Gasoline

Technical specifications

Engine	Ford MSG 425, 2,500 cm ³
Power	51.5 kW / 70 HP - 2,600 rpm
Torque	190 Nm - 2,600 rpm
Unloaded weight	3,750 kg (basic outfit) 8,267 lbs
Water tank	1,450 l 383 gal / Optional 1,600 l 423 gal / 2,200 l 581 gal
Snow tank	4.1 m ³ / compacted 5.1 m ³ 145 ft ³ / compacted 180 ft ³
Transmission	Continuously adjustable hydraulic all-wheel drive
Fuel tank	52 l 14 gal
Hydraulic oil tank	65 l 17 gal
Speed	0 - 13 km/h 0 - 8 mph
Tyres	225 / 75 / R16 C 6 rows of spikes
Wheel rims	8" x 16"



Standard equipment

Cab with heated windshield in safety glass, windscreen wiper system and interior light
PLC control
7 inch colour display
USB port for installing updates and data exchange
Button for automatic mode: Operations start automatically in a predefined order
Spring-suspended and height-adjustable driver's seat (fabric)
Armrest with storage capacity
Power steering
Easily-accessible engine compartment (tiltable) with cab support
Hydraulic oil cooler
Water and fuel tank made of PE
Function for automatic water filling system with immobilizer
Coated snow tank
Snow bin & water tank connection (> 2,750 l / 726 gal)
Footbrake and parking brake
Hydraulically driven and swivelling side brush
Board guide pulley
Rear mirror
Front headlights, snow bin headlight, side headlight
Flashing warning light
Acoustic signal for reverse drive, snow bin cover operation, reverse of the screw conveyors and blade exchange
Proportional water metering
System for water dosing in curves
Conditioner made of stainless steel
Constant grinding pressure conditioner
Quick-Change-System for fast blade replacement (< 60 seconds)
2 blades in wooden transport box (super-light blade - 3.5 kg / 7.7 lbs)
2 towels
Scope of delivery-set



In compliance with Suva certification No. E 7139/2.e

Dimensions

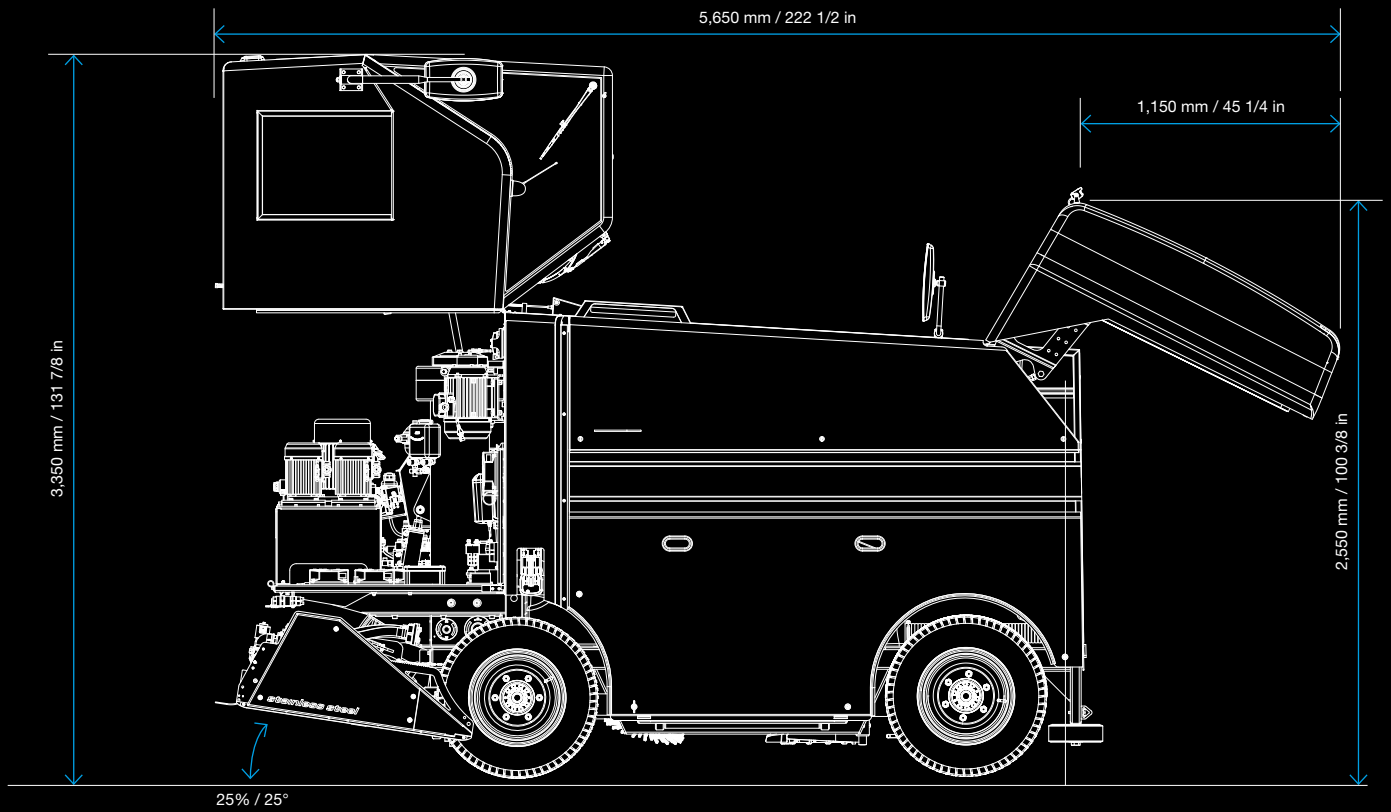
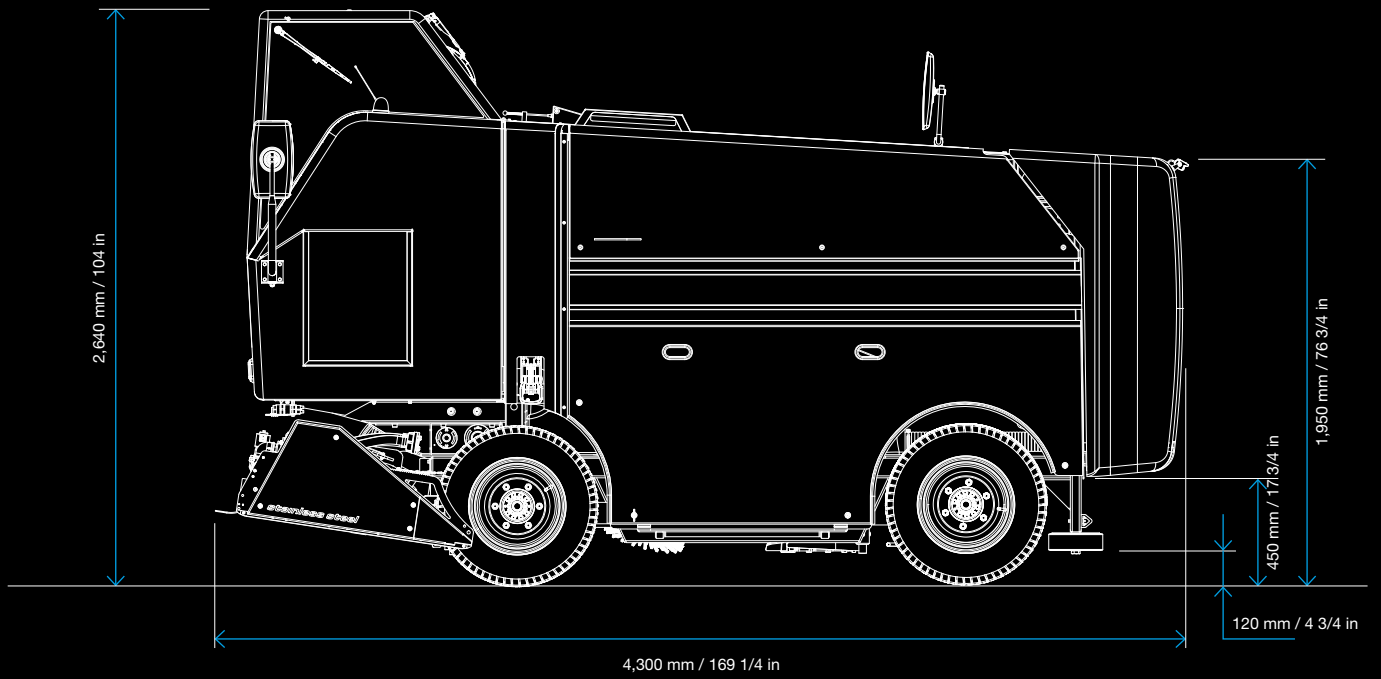

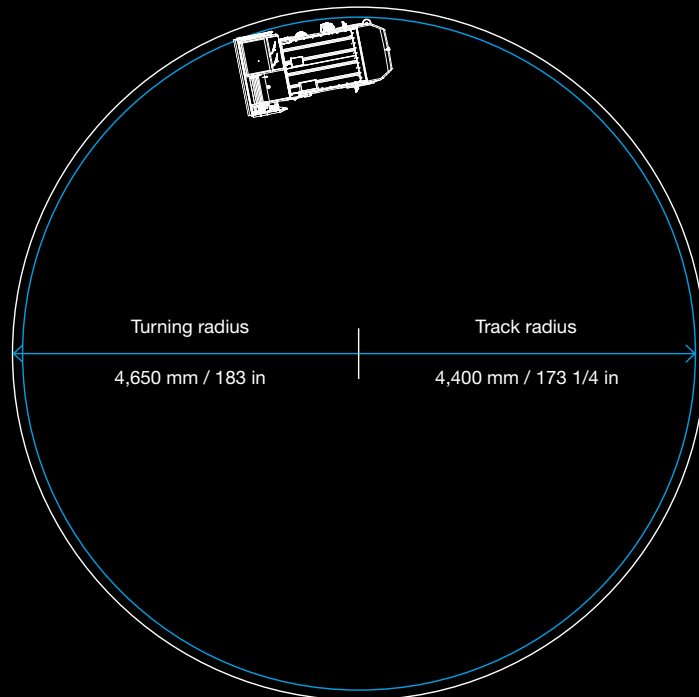
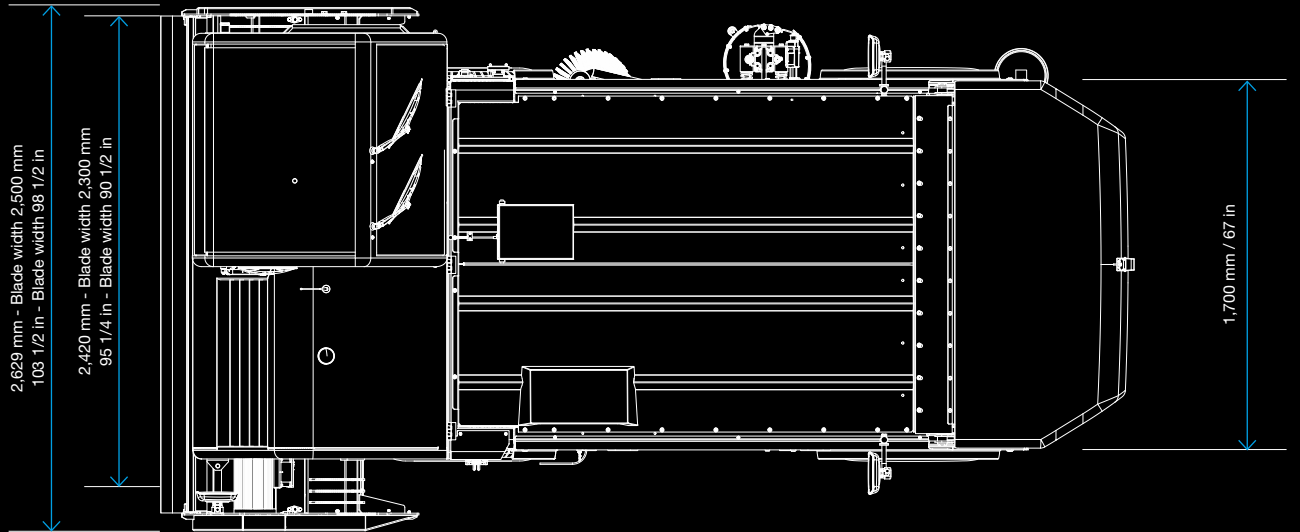

WM technics GmbH

Breiner Straße 15
I-39053 Blumau
T. +39 0471 353 332
info@wm-technics.com
wm-technics.com

