

# A revolution in slope-tool carrier



Catalogue  
Vitrac





Catalogue  
Vitrac

# INDEX

Plus	8
Highlights	14
Facts & Figures	32
Optionals	36
Accessory	40
Company	71
Products	79

# Vitrac – the new generation of tool carriers

Designed for heroic viticulture,  
Vitrac delivers unmatched  
stability and traction.



# With Vitrac, we introduce a new generation of tool carriers for viticulture designed for **terraced vineyards, steep slopes, and confined spaces.**

Vitrac combines excellent handling and flexibility, delivering a unique driving experience – even on extreme inclines. Additionally, it supports a wide range of accessory units.



Weight

Basic machine 750 kg / 1,650 lbs



Performance

18.8 kW (25.6 hp)



Steering

± 80°

“Only Vitrac is this straightforward and versatile!”

Armin & Karl Platter -  
Winemakers

Mockhof, Bozner Leitach





Plus

# Specialized consulting

We aim to maximize your agricultural efficiency and help you get the most out of your fields. Field preparation is crucial in ensuring efficient machine use and achieving optimal results.

For this reason, we offer a specialized consulting service for soil preparation. Our team of experts, with their in-depth knowledge of various soil types and the most effective cultivation techniques, can assist you in selecting the best strategies for adequate soil preparation.



---

Higher productivity

---

Cost optimisation

---

## Consulting

Our team of expert consultants will support you from the very beginning of the project, advising you on optimizing vineyard layout, determining maneuvering areas, and calculating row and plant spacing to maximize the number of vines per hectare or acre.

## Soil preparation

After loosening the soil and distributing the topsoil, the next step is to prepare the foundation and level out irregularities. The topsoil is then reapplied in layers. For steep slopes, the terrain can be prepared using a tracked bulldozer. A spider excavator ('Hupfer') is recommended on extreme inclines, which requires more time.

## Terracing

Depending on the slope, terraces can be constructed using a mini excavator, an auger, or a spider excavator. Terracing with a mini excavator is slower, but the ground remains more stable and compact, and the embankment is formed in a shorter time. Terracing with an auger is faster, but the resulting overhang must be manually removed, and the terraces must be reworked. Unlike the mini excavator, the auger does not excessively compact the soil.

## Construction & planting

With Vitrac, all materials needed for vineyard infrastructure (wire ropes, posts, anchoring hooks, etc.) can be transported directly to the vineyard. The supporting structure can also be assembled before terracing, depending on the bulldozer used. The new vineyard can then be grassed to enhance soil stability and prevent erosion.



Plus

# Agile & safe

Vineyards on steep slopes define the landscape of many regions, creating distinctive cultivated terrain. Whether the vines are arranged on terraces or planted to run directly up and down the hillside, terracing often represents the only economically viable method for operating a vineyard and producing high-quality wines in these challenging environments.

Until now, steep vineyard terraces with narrow paths between vines and low pergolas have only been cultivable through intensive manual labor. To make vineyard work less demanding for winemakers, mechanic Willy Mulser collaborated with South Tyrol vintners to develop the Vitrac tool carrier.



---

Reduced risk of erosion & slipping

---

Safe handling

---

Ability to operate on flat terrain

---

The vehicle was designed explicitly for **terraced vineyards** on extremely steep slopes with **narrow rows** and **difficult terrain**.

### Stability on steep slopes

The Vitrac tool carrier delivers outstanding stability even on the steepest slopes. Perfect balance at the front of the machine is achieved through the strategic placement of the internal combustion engine and centrally positioned hydraulic components. The driver's weight is concentrated directly above the wheel's central point, which also houses the atomizer, ensuring excellent balance throughout the rear section.

Due to the machine's optimal balance, the central joint is subjected to virtually no load. Other structural elements, such as the intelligent central joint lock, the engine guard, the rollover bar, and the escape routes on three sides, further enhance work safety.

### Horizontal terraces with horizontal rows

Vineyards on slopes exceeding 10% should be terraced. In these terraced vineyards, rows are dug into the hillside to run as horizontally as possible. After each row, an embankment elevates the terrain to the next level. The design should incorporate several empty runs between rows.

### Turning area & radius

Setting up turning areas significantly increases driving safety. On steep terrain, the turning area is often bolstered with concrete, stone, or geo walls.

For a total width of 90 cm / 3.0 ft  
Inner turning radius: 425 mm / 1.4 ft  
Outer turning radius: 1,325 mm / 4.4 ft

Its dual articulation allows Vitrac to reach a turning angle of around 80° without losing stability.

### Designing & adapting terraces

To support the smooth operation of machinery, terraces should be maintained regularly.

## Row width

With an overall length of 2.25 m (7.4 ft) or 2.55 m (8.4 ft) and a width of 80 cm (2.6 ft), and thanks to its highly stable steering, Vitrac can move directly into the next row without requiring multiple maneuvers, even with a row spacing of just 1.30 m (4.3 ft). The only requirement is to ensure the rear end remains aligned as the front section passes through.

## Terrace care

Horizontal terraces require regular maintenance to ensure optimal machine operation. Depending on the soil type, terraces may degrade at varying rates over time, losing width and becoming more difficult to navigate. Regular maintenance on maneuvering points and row spacing improves safety conditions and facilitates easier work.



Highlights

# Operation & comfort

Everything is within reach and under control, ensuring maximum safety and agility while driving.



---

Air-suspended comfort seat

---

Effortless control of accessory units

---

The right joystick: a true multitool

---

Control Panel

---



## Air-suspended comfort seat

Maximum seating comfort is crucial for long working hours. That is why we have developed an ergonomic driver's station that makes driving the slope-tool carrier extremely comfortable. Rubber buffers absorb shocks and vibrations, and all GRAMMER air-cushioned reversible seat functions can be controlled easily by a joystick, guaranteeing a high degree of driving and operating comfort in both directions.



## Effortless control of accessory units

It couldn't be easier: using a multifunction joystick, you can operate all hydraulic and electric functions, such as switching lights on and off, with your left hand.

This allows you to set the rotation direction and control the oil flow of the hydraulic PTO independently of the diesel engine's speed. The joystick adapts its functions based on the attached accessory unit, and the machine automatically optimizes all parameters for the recognized accessory.



## The right joystick: a true multitool

One of the greatest technical innovations lies in the right-hand multifunctional joystick: with a simple 60° rotation in either direction, the machine achieves an unparalleled steering angle of +/- 80°, further enhancing Vitrac's outstanding maneuverability. This joystick also operates the differential lock, the activation button, the direction reversal, the throttle control, and the cruise control – all with the right hand, ensuring maximum safety and ease of use even after hours of work.



## Control Panel

All relevant information can be seen on the control panel: Temperatures, speed, daily distance, and overall distance or maintenance intervals. Individual settings can be accessed for the accessory unit attached. The ignition switch and the control unit for the diesel engine are easy to reach and well-protected.

Driving speed can be continuously adjusted up to 10 km/h / 6 mph using the ergonomic pedal. The left footboard is angled to provide secure footing even on steep terrain.



## Multifunction display (optional)

The Vitrac color display clearly shows all the relevant information for each accessory unit. If the sprayer is attached, for example, the display will indicate the spray pressure, the air deflectors' position, and each nozzle's on-off status. The display also provides information on lifting power and float settings for the built-in hoist. The user can select the standard and additional equipment settings from the menu and adjust them according to requirements.

# Maneuverability & soil preservation

# Easy steering thanks to the double articulation joint.



## Double articulation joint

Extremes are no problem for Vitrac: With its dual articulation, this vehicle can manage a turning radius of about 80° without losing stability. The central positioning of the central joint means that the turning axle runs parallel to the vehicle's longitudinal axis even during steering, and the electric proportional valves allow even the slightest steering movements to be carried out with absolute precision.

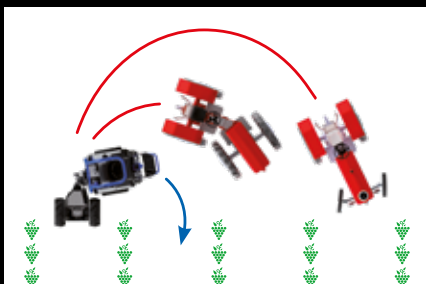

## Narrow, compact & maneuverable

With a wheelbase of 1.325 m (4,35 ft), a width starting from 80 cm (2.6 ft), and a stable steering system, Vitrac can enter the next row (minimum width of 1.30 m / 4.3 ft) in a single maneuver. The only requirement is to carefully guide the front section through to ensure the rear end remains stable and avoids drifting.



## Perfectly balanced

Vitrac's front section is perfectly balanced, as the internal combustion engine and the hydraulic components are laid out centrally, with the driver's weight positioned above the center of the wheel. The back section of the truck is also balanced, as the sprayer is located above the center of the wheel. The entire machine is, therefore, in perfect equilibrium with barely any pressure on the central joint.



## Stable frame

Vitrac combines maximum stability with lightness. The intricate structure of the high-tensile steel frame is both lightweight and stable. The underside is armored with front and rear steel panels to prevent damage from collision. The central joint also guarantees perfect ground adjustment.



## Soil protection thanks to low weight

The truck's weight is kept at a low 750 kg / 1,650 lbs to protect the soil's sensitive ecosystem. With an optional tire width of 25 cm / 10 in, ground pressure remains minimal. The symmetric design of the frame and steering ensures precise wheel tracking, reducing strain on the drivetrain and making the vehicle gentle on the ground.

# Performance & efficiency

# Outstanding components to ensure superior performance and maximum efficiency.



## Compact & reliable engine

Vitrac is powered by the KDW 1404, a modern, compact, low-maintenance engine by Kohler that weighs only 98 kg / 216 lbs. Its low profile and deep positioning in the frame ensure a low center of gravity. The engine steering assembly is located in the cylinder head and is driven by a belt. This four-stroke diesel engine features a cast iron cylinder block and a water-cooled design, with the engine head made of a special aluminum alloy. Operating at a working speed of 2,600 rpm, the engine is both fuel-efficient and low-noise.



## Effective cooling in extreme heat

Thanks to its large radiator, Vitrac stays cool, even on scorching days, efficiently cooling the hydraulic oil and engine under high external temperatures. The protective grille can be easily removed without tools for cleaning, simplifying maintenance, and ensuring the cooling system runs at peak performance. The Cleanfix reversible fan is available as an optional.



## Low-maintenance air filter

Before the air even reaches the filter, it is pre-cleaned by an additional cyclone separator.



## Highly efficient hydraulic pumps

Vitrac's diesel engine drives an electronically regulated dual axial piston pump: the first pump, responsible for propulsion, supplies 96 l / 25.4 gal of oil, while the second pump, delivering 46 l / 12.2 gal at 250 bars, powers the accessory units. Additionally, there are two gear pumps for steering and cylinder movement. All hydraulic components ensure optimal efficiency and a long service life.



## Off-highway electronic components

Only electronic components tested and designed for off-highway applications control the vehicle. Where possible, shortcut-proof and overload-proof components have been substituted for all mechanical safeguards and switching elements so that nothing can get in the way of trouble-free and comfortable operation!

Highlights

# Hydrostatic drive

## Innovative all-wheel drive for higher performance

The hydraulic all-wheel drive with planetary gear is ideal for special requirements on rough terrain: Power is distributed perfectly, and a high starting torque and gentle power transmission are ensured. The series-parallel hydraulic drive connection also ensures exceptionally high traction.

## Self-braking system

Owing to the self-braking hydraulic motor, Vitrac cannot move forward unless the driver gives the command. Regardless of the terrain, the vehicle slows down automatically when the accelerator is released, turning a hill start into child's play.

## Spring-loaded brakes for increased safety on steep slopes

The 4 spring-loaded brakes – one in each drive wheel – ensure a safe shutdown when the drive joystick is released, the driver's station is vacated, or the diesel engine is stopped.

## Differential lock

The differential lock stops the wheels from spinning and can be turned on and off within a split second, even under full load. That means the power is equally distributed to all four wheels, even in extreme situations.

## Speed controller

If required, electronic cruise control will keep the selected speed consistent so that spraying agents can be spread evenly. It is also an advantage when mulching or using various accessory units. Independent of the diesel engine speed, the set speed is regulated precisely and quickly by the speed sensors in the drive motors.

## Robust drive control

Vitrac masters even the toughest terrain: its highly sensitive drive software enables precise maneuvering.

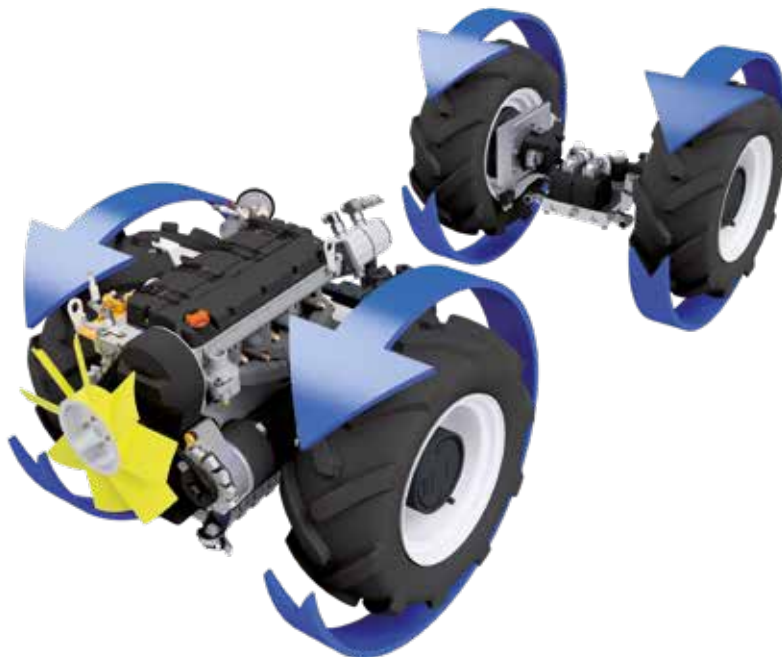

Highlights

# Versatility

# Quick & easy driver's station rotation & accessory unit changes.



## Reversing the driver's seat – quick & uncomplicated

Vitrac's reversible seat allows the driver to operate front and rear machinery. Both the seat and all control elements can be reversed by 180° – all without needing tools. The roll cage can also be adjusted, and the footrest and accelerator can be repositioned. The center of gravity remains unchanged, as the pivot point is located centrally above the front axle.



## Quickly change accessory units

Vitrac offers numerous accessory units to support you throughout the season. The innovative slope tool carrier is designed for quick and effortless unit changes: after installing the support feet, remove the fixing bolt and disconnect the hydraulic and electrical connections. The rear center bolt also enables straightforward attachment of the accessory unit.



## Automatic recognition of accessory units

Innovative and intelligent: The vehicle automatically detects which accessory unit is attached and perfectly adjusts all unit settings, including oil quantity and operating components. The accessory unit has 11 programmable electric outputs for controlling hydraulic valves and 7 analog, digital, and encoder inputs. Furthermore, a CAN bus interface enables Vitrac to manage even the most complex accessory units.



## High-performance hydraulic PTO

Vitrac is equipped with a high-performance hydraulic PTO as standard. Its pump can supply up to 46 l / 12.2 gal per minute. The diesel engine's power is hydraulically transferred to the accessory unit without turning shafts, eliminating twist torque between the front and rear of the truck and, hence, minimizing the risk of tilting.

Highlights

# Safety

Uneven terrain can pose a risk of tilting.  
Vitrac reliably mitigates this by **locking the central joint** in the correct direction.

All potential dangers are detected by an intelligent control system that monitors each wheel's ground pressure using sensors. When a wheel loses ground pressure, the joint lock is activated, and a warning signal is emitted.





## Engine protection switch

If Vitrac tilts in extreme situations, the diesel engine automatically shuts down immediately, preventing oil suction and potential engine damage. A specially developed float gauge in the hydraulic reservoir cap also helps prevent hydraulic oil leakage.



## Protective roll cage

Two roll cages are designed to protect the driver and the slope tool carrier in the event of tilting: a high cage specifically developed for head protection and a low cage designed for pergolas. The roll cages can be switched out without tools when reversing the seat.



## Reliable underbody protection

Totally safe: The high-strength steel plates on the underside withstand even hard stones, shielding all mechanical and electrical components. Additionally, enclosed wheel-casing prevents vine branches, grass, and similar debris from entering the engine compartment.



## Steady on slopes

Vitrac's stability is due to its low center of gravity, essential for secure and efficient operation on steep slopes. The diesel engine and hydraulic pumps are positioned as low as possible, near the machine's heavy steel base frame. The upper components, such as the lightweight aluminum cabin, are crafted using techniques typically used in the aerospace industry.



## Exit the vehicle from three sides

While entry is from the front, the vehicle can be exited from the right or left side in an emergency by pushing the armrests outward.

Highlights

# Customer satisfaction

# Less maintenance means more productivity: here, forward-thinking design makes all the difference.



## Instant maintenance

Maintaining the engine compartment has never been easier. Tilt the driver's seat sideways – without tools or removing the attached accessory units.



## Easy service intervals

Vitrac monitors maintenance costs: after 100 hours of operation, the slope tool carrier only needs to be serviced every 250 hours or every 2 years. A signal on the display reminds you of the next service. These relatively large intervals are due to the truck's high-quality components and generous filters.



## Simple troubleshooting

Potential faults are shown to the driver directly and clearly on the display.



## The right spare part at all times

Order your spare parts quickly and conveniently from our WORKspace: Our series number and digital image system help you to find any part you need with just one click.



## Quality guarantee

Vitrac is a product that is developed, manufactured, and assembled at our facility. By doing so, we can guarantee top quality and on-time delivery.

## Facts & figures



### Vitrac

Engine	Kohler diesel engine KDW1404E525	Steering	Double articulation (+/- 80°)
Weight	Basic machine 750 kg / 1,650 lbs	Central joint lock	Central location with patented joint lock system and independent wheel monitor
Perm. total weight	1,400 kg / 3,086 lbs	Service brake	Hydrostatic
N. of cylinders	4	Parking brake	Hydraulically controlled negative brakes on all 4 wheels, integrated in the end drives
Performance / rpm	18.8 kW (25.6 hp) / 2,600 rpm	PTO	Can be regulated hydraulically via piston pump in both directions 250 bar from 0 to 46 l / 12 gal
Displacement	1,372 ccm / 83.7 in <sup>3</sup>	Working hydraulics	Gear pumps max. 12 l / 3.2 gal and 130 bar, electrohydraulic proportional valves, hydraulic accumulator
Drive	Stepless, hydraulic all-wheel drive (0.2 - 10 km/h / 0.1 - 6 mph) with electronic speed control		
Axles	Hydraulic single-wheel drive via planetary drive		
Differential lock	Powershift hydromechanical differential lock		

## General

Driver's station	Supported by 4 rubber buffers, rotatable by 180°, pedal position can be set, 2 multifunction joysticks for operation	Tires	<ul style="list-style-type: none"> <li>Standard: 5.70 - 12 with 3.0 bar air pressure Width: 80 cm / 31.5 in</li> </ul>
Seat	Air-cushioned, longitudinally and height adjustable, synthetic leather cover, back height and incline adjustable, armrests: independently height, longitudinally and laterally adjustable	Optional	<ul style="list-style-type: none"> <li>23 x 8.50 - 12 10PR with 1.5 bar air pressure Width: 90 cm / 35.5 in</li> <li>23 x 10.50 - 12 10PR with 1.0 bar air pressure Width: 102 cm / 40 in</li> </ul>
Instruments	Speed display with integrated operating hours counter, control lights, and fuel supply display; Multifunction instrument with output of cooling water temperature, hydraulic oil temperature, speed, cruise control, PTO state, as well as menu display for user-specific settings and system data	Wheel base	<ul style="list-style-type: none"> <li>1,325 mm / 4,35 ft</li> </ul>
Hand-arm vibrations	< 2.5 m/s <sup>2</sup> / < 8.2 ft/s <sup>2</sup>	Total length	<ul style="list-style-type: none"> <li>255 cm / 8.4 ft with seat in the standard driving direction</li> <li>225 cm / 7.4 ft with seat in the reverse driving direction</li> </ul>
Whole-body vibrations	< 0.5 m/s <sup>2</sup> / < 1.6 ft/s <sup>2</sup>	Height	<ul style="list-style-type: none"> <li>With low roll bar: 150 cm / 4.9 ft</li> <li>With high roll bar: 190 cm / 6.2 ft</li> </ul>
A-weighted sound pressure level at the driver's seat	<ul style="list-style-type: none"> <li>Vitrac without implements: LAeq = 85,0 dB</li> <li>With mulcher, without load: LAeq = 90.3 dB</li> <li>With sprayer LAeq = 90.7 dB</li> </ul>	Operating temperature	<ul style="list-style-type: none"> <li>-15 °C to +40 °C / 5 °F to 104 °F</li> </ul>
A-weighted sound power level	<ul style="list-style-type: none"> <li>VITRAC without implements: LWA = 102.8 dB(A)</li> <li>With mulcher, without load: LWA = 105.4 dB(A)</li> <li>With sprayer LWA = 108.0 dB(A)</li> </ul>	Turning radius with overall width of 90 cm / 3.0 ft	<ul style="list-style-type: none"> <li>Inner turning radius: 425 mm / 1.4 ft</li> <li>Outer turning radius: 1,325 mm / 4.4 ft</li> </ul>
Electric system	12V 44Ah, light system 33A, CAN bus and 20 electrical outputs/inputs for accessory units		
Fuel tank	20 l / 5.3 gal		
Hydraulic system	25 l / 6.6 gal (type HVLP 46)		

# Dimensions

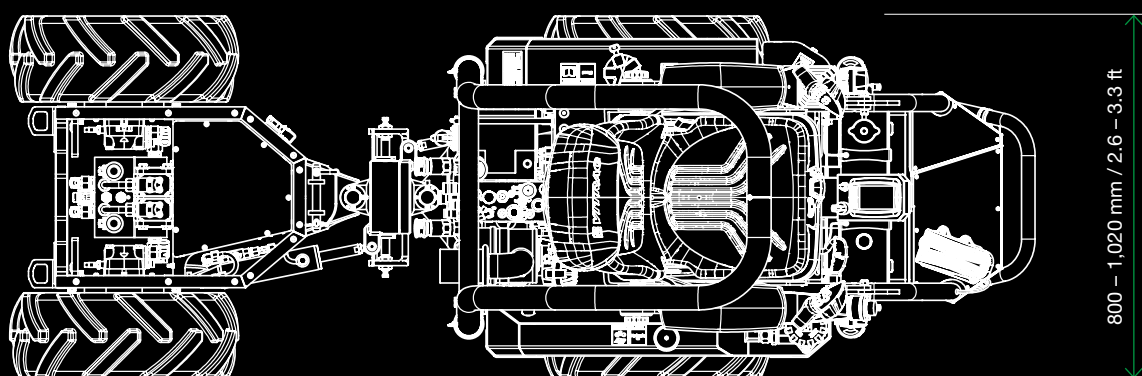
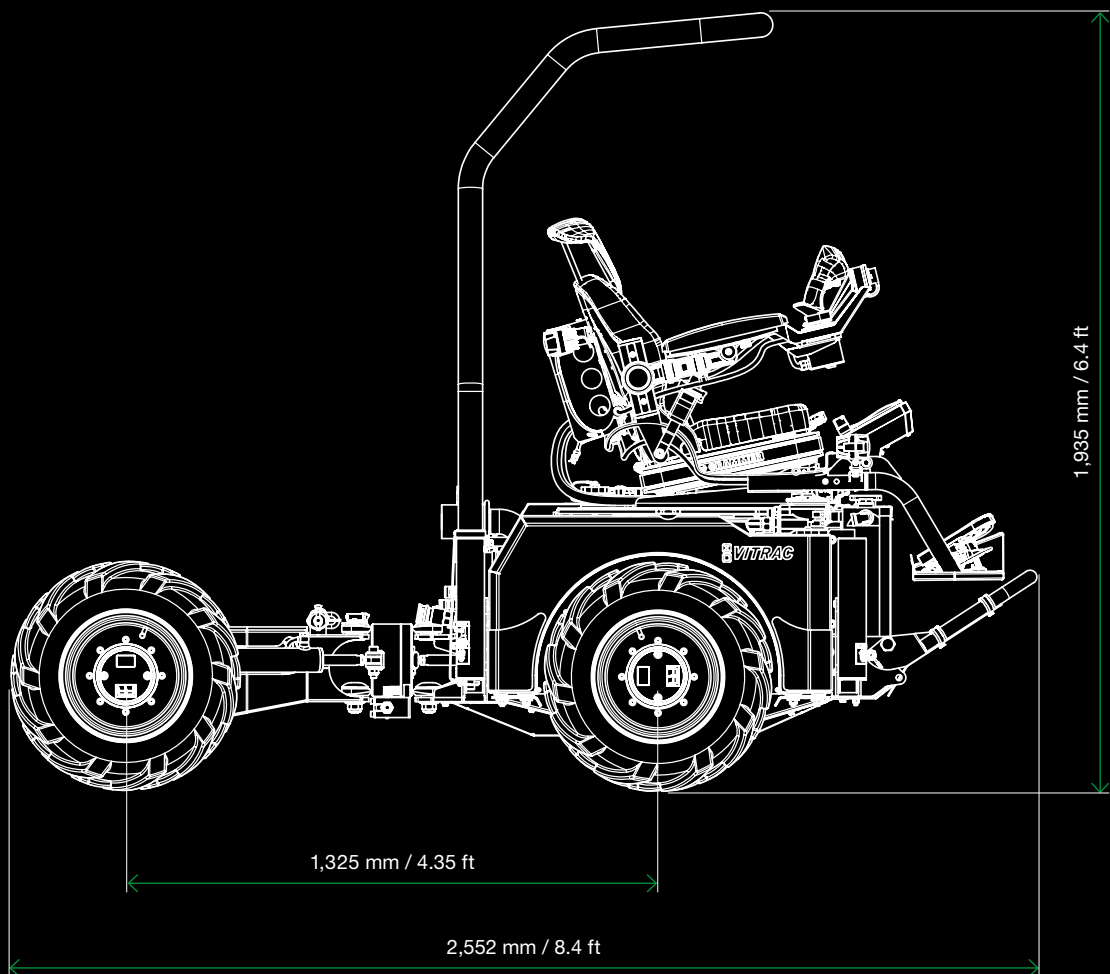

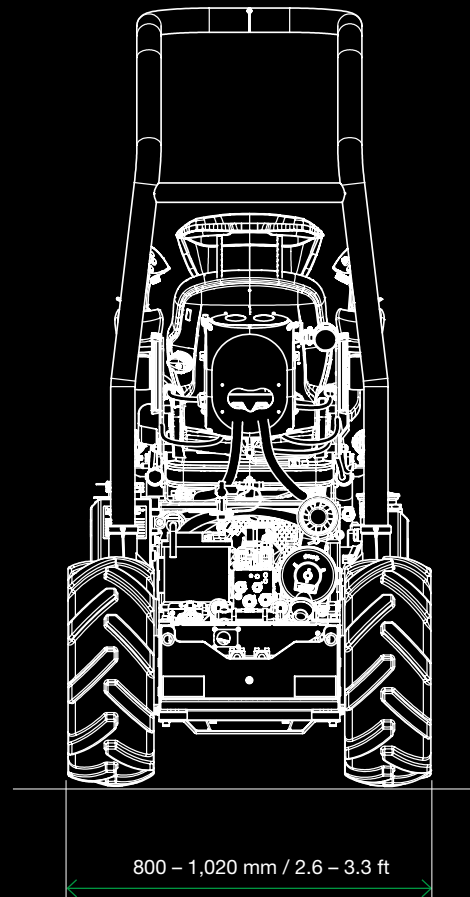
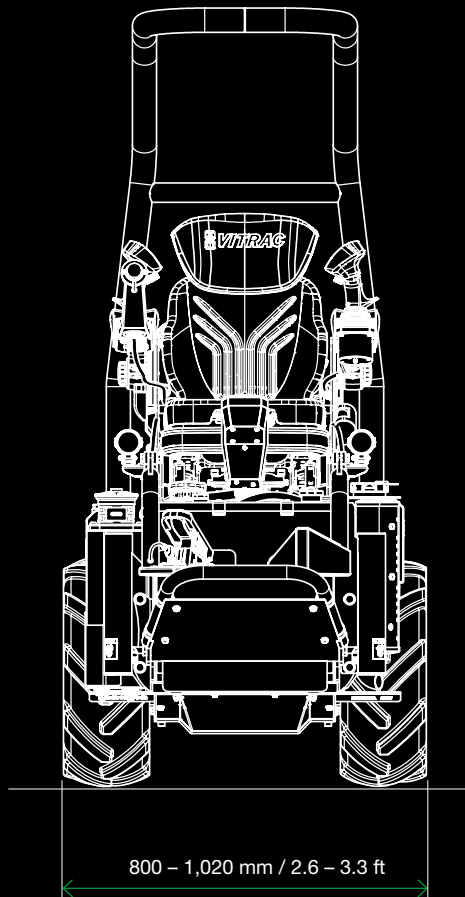

## Turning radius

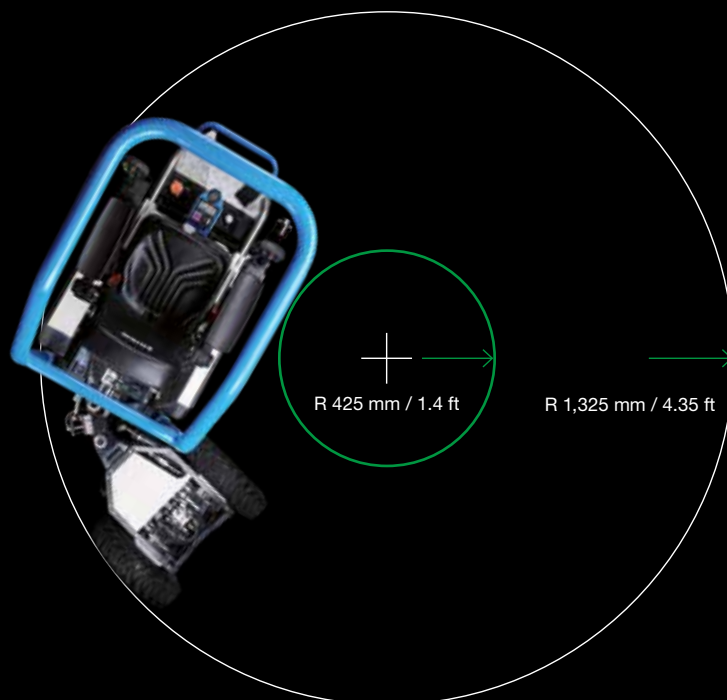

# Vitrac

Vitrac perfectly adapts to your specific requirements. Each accessory boosts your productivity while creating a truly personalized work experience.



# Optionals



Cleanfix  
reversible fan



Color  
display



Road  
homologation kit  
*(Lights, horn, rear-view mirror,  
registration plate, holder)*



LED  
work lights



12V socket  
DIN 9680



Radiator  
protection



Reflector kit  
*(front & rear)*



Transportation  
box



3 mm  
polycarbonate  
glass



Protective  
seat cover  
*(UV and weather resistant)*



Product warranty  
extension  
*12 + 12 calendar months  
max. 1,000 operating hours*

# Tires



## Standard

Standard: 5.70 - 12 with 3.0 bar air pressure  
Width: 80 cm / 31.5 in



## Optional 1

23 x 8.50 - 12 10PR with 1.5 bar air pressure  
Width: 90 cm / 35.5 in



## Optional 2

23 x 10.50 - 12 10PR with 1.0 bar air pressure  
Width: 102 cm / 40 in



---

## Spiked wheels

---

## Dual tires



2 rows

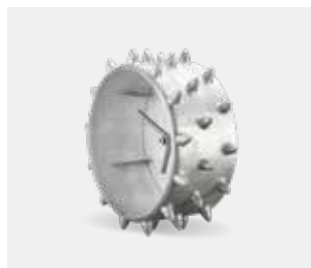

3 rows



## Accessory

# Linkage

Standard linkage, mount plate with quick-release hook cat. 1 - 2, hydraulic system.

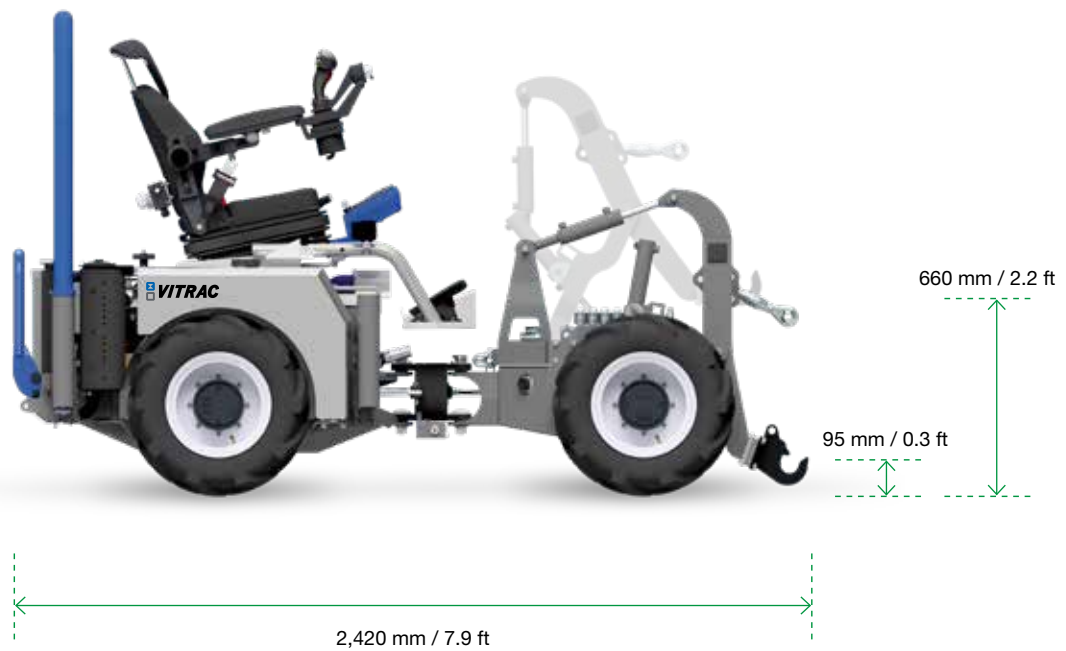

## Technical data

Lifting capacity

500 kg / 1,100 lbs

# Configuration



Linkage



Hydraulic distributor with 1 free cylinder for additional movements



Hydraulic top link



Mounting frame Cat. 1



Three-point mounting frame Cat. 1, pivotable ( $\pm 8^\circ$ )



Three-point mounting frame Cat. 1, pivotable ( $\pm 15^\circ$ ) and with side shift



Quick-release hooks Cat. 2S,  $\varnothing 22$



Quick-release hooks Fendt  $\varnothing 22$



PTO OMP 100 cc



Parking jacks

## Linkage available with



Loader bucket



Rotary plough

## Linkage compatible with other manufacturers

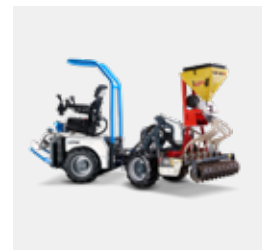
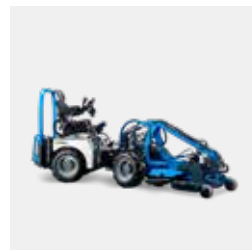
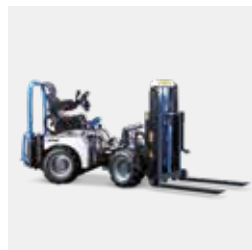

# Loader bucket

Vitrac linkage + loader bucket

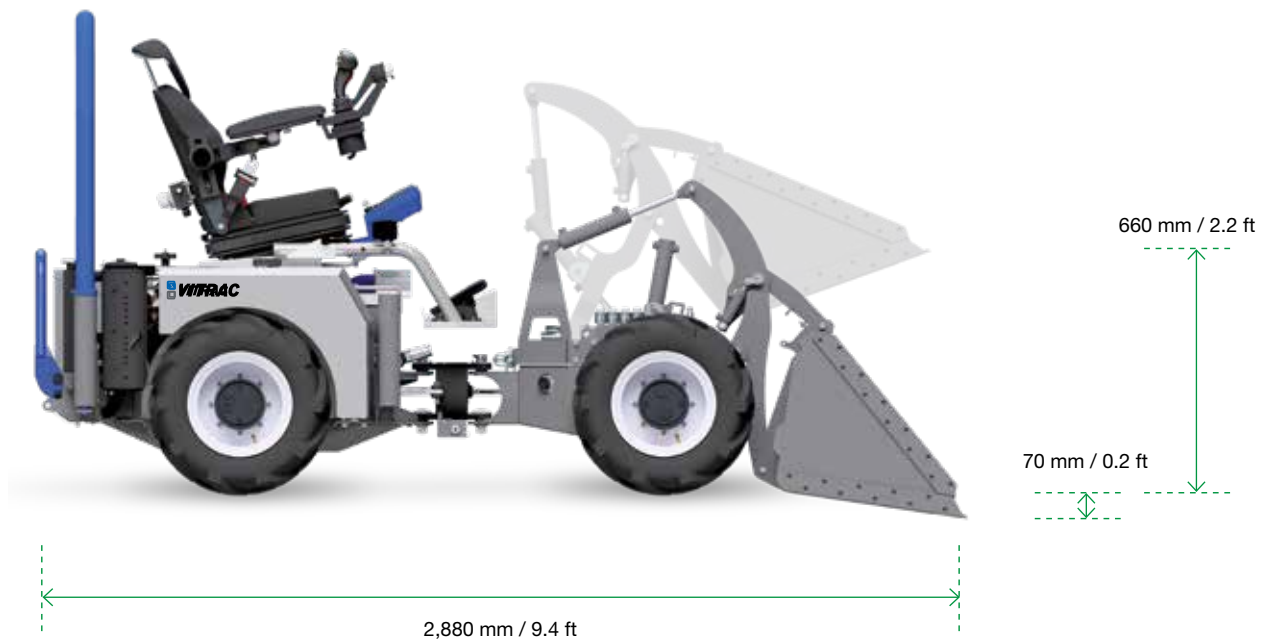

## Technical data

Width	900 mm / 35.5 in
Volume	0.16 m <sup>3</sup> / 5.5 ft <sup>3</sup>



## Accessory

# Rotary plough

In terracing, the rotary plough is your indispensable ally, ensuring fast and hassle-free processing of terraced surfaces and turning areas.

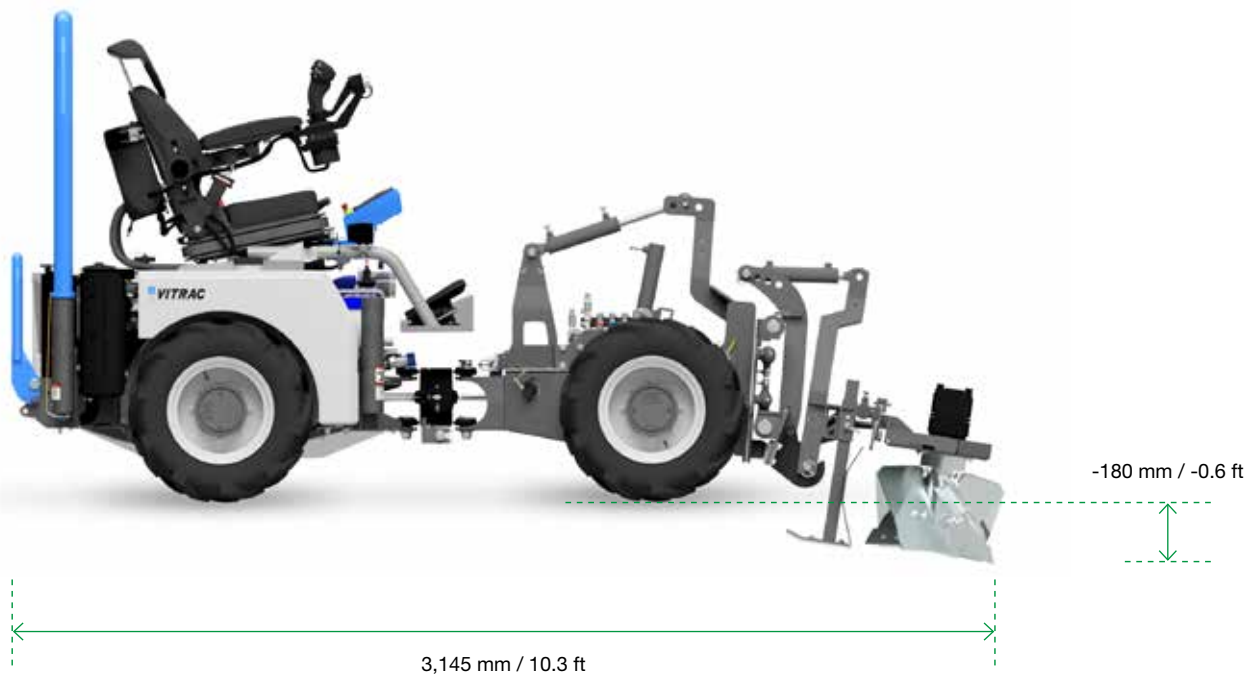

## Technical data

Width	800 mm / 31.5 in
Side shift with oscillating hitch frame	<ul style="list-style-type: none"><li>• <math>\pm 100</math> mm / <math>\pm 4</math> in</li><li>• with oscillating hitch frame <math>\pm 150</math> mm / <math>\pm 6</math> in</li></ul>
Inclination with oscillating hitch frame	$\pm 15^\circ$
Required hydraulics	40 l/min at 200 bar / 10.5 gal/min at 200 bar
Necessary hydraulics for cylinder movement	min. 10 l/min at 130 bar / 2.5 gal/min at 130 bar
Rotational direction	Left & right
Weight	165 kg / 365 lbs



## Accessory

# Sprayer SP 200-60

The SP 350-60 sprayer stands out for its compact design, 350-liter / 92.5-gallon capacity, and powerful fan. Once attached, its low weight offers a maneuverable, practical, and user-friendly solution that promises maximum efficiency in every application. The fan and metal frame are made of stainless steel, while the tanks are crafted from PE.



## Technical data

Capacity	200 l / 53 gal
Pump	26 l/min at 40 bar, 3 membranes / 7 gal/min at 40 bar, 3 membranes
Aspiration filter	Arag 312
Pressure filter	Braglia M144 with automatic return
Agitator	Hydraulic
Nozzles	10 pieces Albus
Air flow rate	22,500 m <sup>3</sup> /hour / 793,000 ft <sup>3</sup> /hour
Maximum pressure	40 bar
Required hydraulics	40 l/min / 10.5 gal/min at 200 bar
Illumination	Optional, powerful LED lighting
Weight	when empty 140 kg / 309 lbs when full 390 kg / 860 lbs

---

# Products

## Round-flow fan

The round-flow fan is designed to meet the unique requirements of low pergola systems.

SP 200-60R



## Cross-flow fan

SP 200-60Q



# Configuration



Sprayer



Radial cross flow  
SP 200-60R



Low cross flow  
SP 200-60Q



Spraying equipment  
from other  
manufacturers

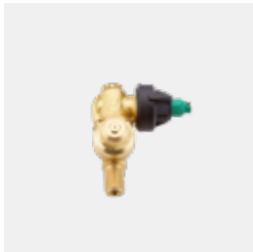

Nozzle holder  
single  
(Quick Cap System)

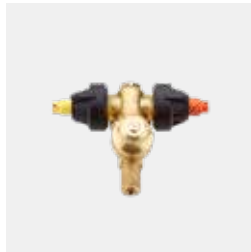

Nozzle holder  
double  
(Quick Cap System)

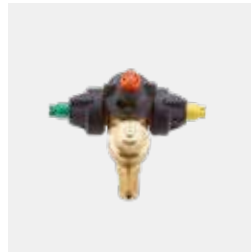

Nozzle holder  
triple  
(Quick Cap System)

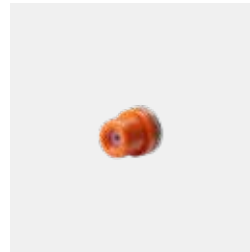

Nozzles Albus  
ATI 80°

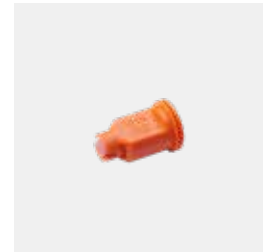

Nozzles Albus  
CVI 80°  
(drift reduction)



Angle sensor



Work light



Pressure sensor



Pressure sensor &  
electric pressure  
regulator



Tank drain valve



Rear light bracket



Parking jacks



## Accessory

# Sprayer HQS 200-60

The HQS 200-60 sprayer creates a uniform airflow over a vast area. The elevated fan position prevents the intake of foreign particles. With minimal overhang and optimized weight distribution, it's ideal for use on highly steep terraced slopes. The fan and metal frame are made of stainless steel, while the tank is crafted from PE.



## Technical data

Capacity	200 l / 53 gal
Pump	26 l/min at 40 bar, 3 membranes / 7 gal/min at 40 bar, 3 membranes
Aspiration filter	Arag 312
Pressure filter	Braglia M144 with automatic return
Agitator	Hydraulic
Nozzles	14 pieces Albuz
Air flow rate	22,500 m <sup>3</sup> /hour / 793,000 ft <sup>3</sup> /hour
Maximum pressure	40 bar
Required hydraulics	40 l/min / 10.5 gal / min at 200 bar
Illumination	Optional, powerful LED lighting
Weight	when empty 180 kg / 397 lbs when full 430 kg / 948 lbs



# Configuration



Sprayer



High cross flow  
HQS 200-60



Spraying equipment  
from other  
manufacturers

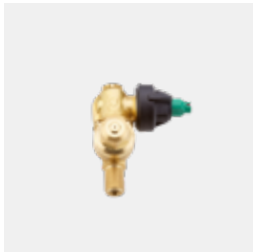

Nozzle holder  
single  
(Quick Cap System)

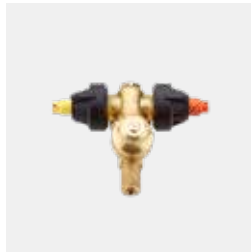

Nozzle holder  
double  
(Quick Cap System)

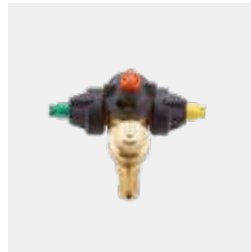

Nozzle holder  
triple  
(Quick Cap System)

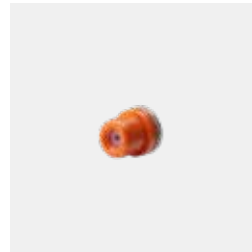

Nozzles Albus  
ATI 80°

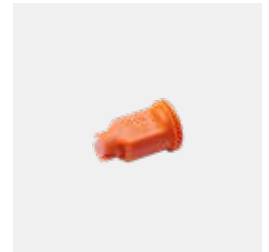

Nozzles Albus  
CVI 80°  
(drift reduction)



Angle sensor &  
hydraulically  
adjustable flaps



Work lights



Pressure sensor



Pressure sensor &  
electric pressure  
regulator



Tank drain valve



Rear light  
bracket



Parking jacks



## Accessory

# Implement mast

The implement mast sets new benchmarks for multifunctionality in farming. It allows you to mount various accessory units, including the flail mower or trimmer, and position them according to your needs. The implement mast takes your productivity to a new level by offering an all-in-one solution for diverse tasks.

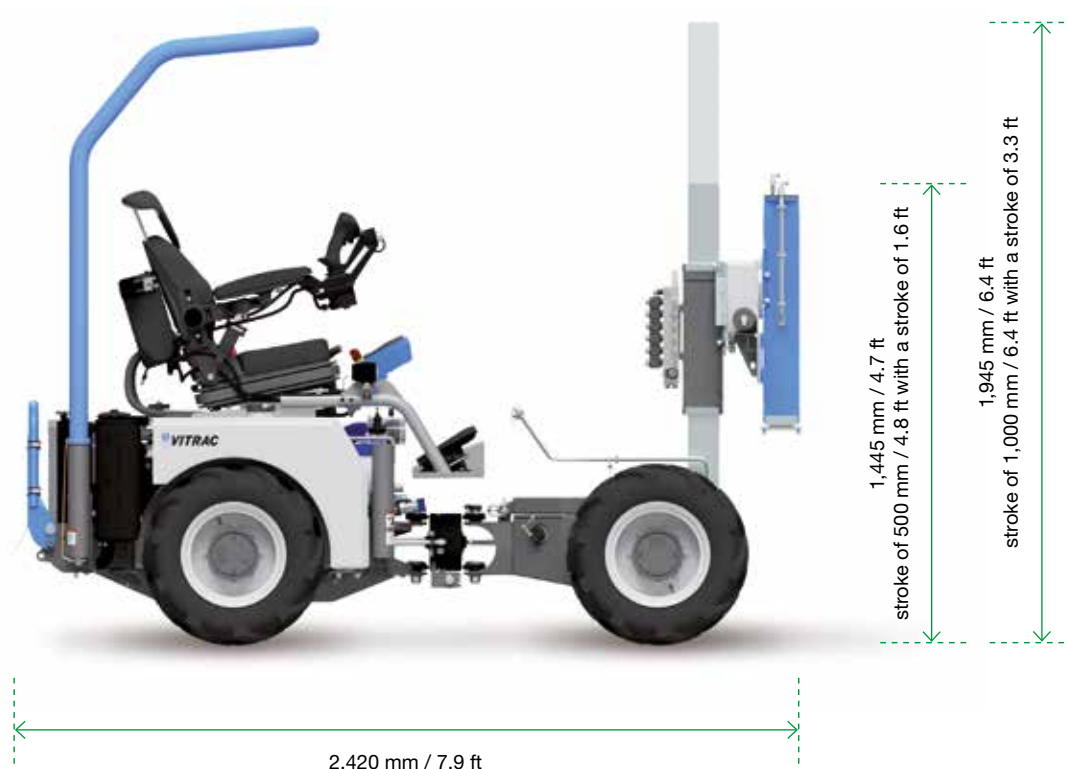

## Technical data

Stroke length of the main telescope	500 mm or 1,000 mm / 1.6 ft or 3.3 ft
Tilt angle of the swivel system	$\pm 90^\circ$
Stroke length of the 2 <sup>nd</sup> telescope	500 mm / 20 in
Weight small mast	170 kg / 375 lbs
Weight high mast	190 kg / 419 lbs

---

# Configuration



Implement mast with hydraulic block unit

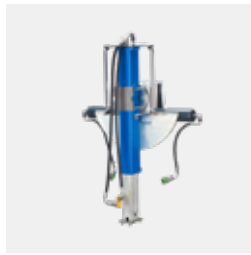

Swivel system with 500 mm telescope



Quick-release system for the telescope



Parking jacks

## Available with the flail mower



Mower model SM80 with a working width of 80 cm / 2.6 ft



Mower model SM90 with a working width of 90 cm / 3.0 ft



Hydraulic shoot remover  
*(on request: individually controllable brush)*



Parking jacks

## Available with the trimmer



Trimmer LSU with hydraulic functions

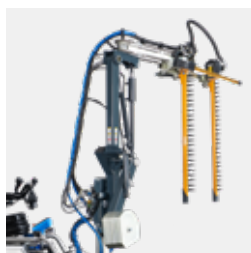

Pellenc cutter bars

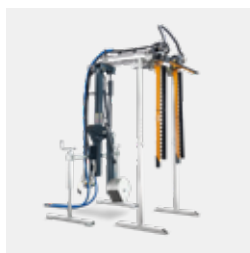

Parking jacks

## with other manufacturers

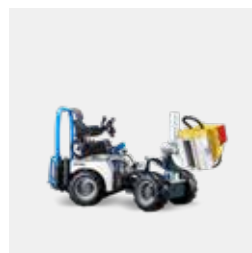

## Accessory

# Flail mower SM

The SM flail mower, mounted on the implement mast, works with Vitrac as a multipurpose mower for vineyards on steep slopes. It is equally well-suited for level terraces and banks. The housing is made of high-strength steel to keep weight low. With the flail mower's compact length relative to the loader, Vitrac remains especially stable and easy to maneuver.

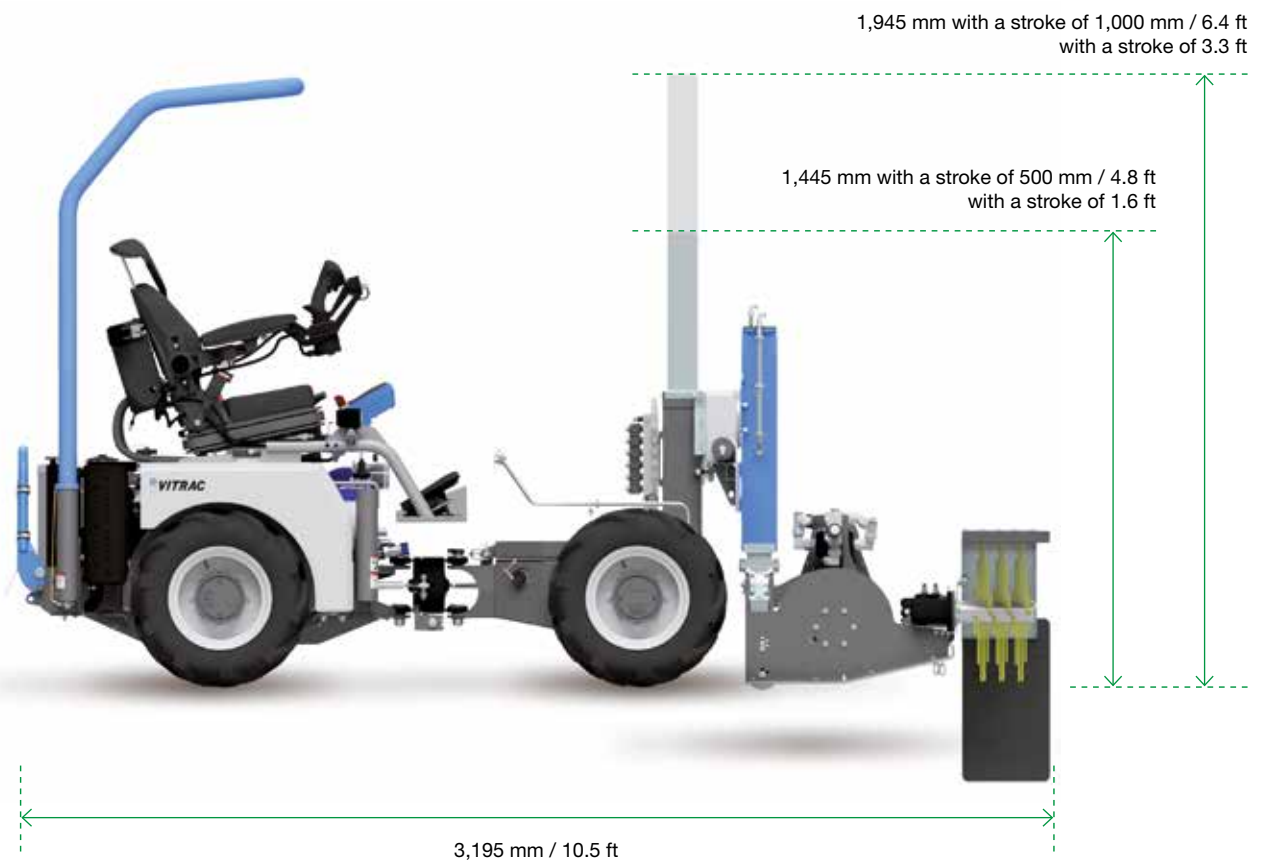

## Technical data

Operating width	800 mm or 900 mm / 31.5 in or 35.5 in
Working rpm	2,000 – 2,600 rpm
Hydraulic system for flail mower axle	min. 40 l/min at 200 bar / 10.5 gal/min at 200 bar
Hydraulic cylinder	7.5 l/min at 130 bar / 2 gal/min at 130 bar
Weight	345 kg or 354 kg / 760 lbs or 780 lbs



## Accessory

# Trimmer LSU

The LSU trimmer was developed for narrow spaces and steep terrain. The deep-set, hydraulic-swivel counterweight guarantees high stability in all working conditions.

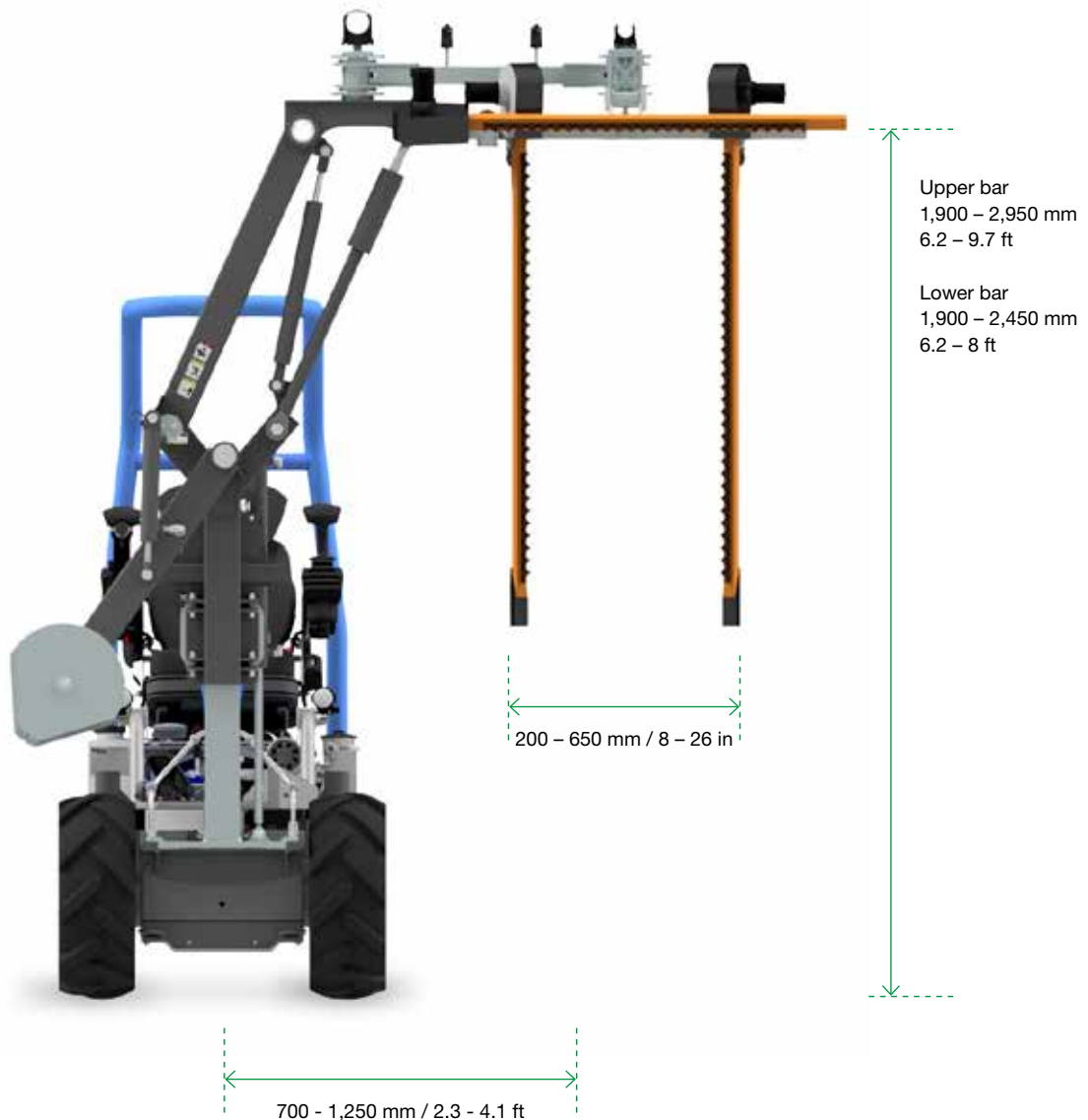

## Technical data

Requisite hydraulics for cutter blades	min. 20 l/min at 160 bar / min. 5.5 gal/min at 160 bar
Hydraulic tilt cylinder	7.5 l/min at 130 bar / 2 gal/min at 130 bar
Length of cutter bars	900 – 1,200 mm / 35.5 – 47.5 in
Weight	410 kg incl. counterweight / 900 lbs incl. counterweight

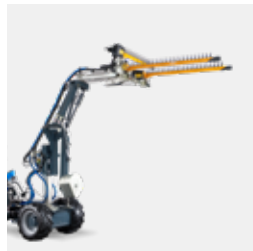
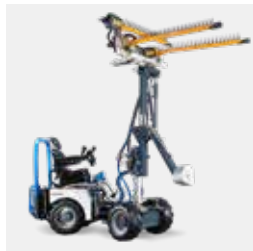
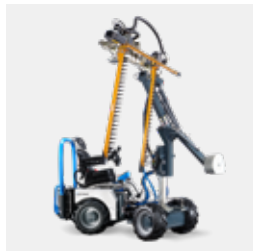
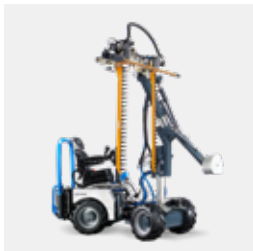
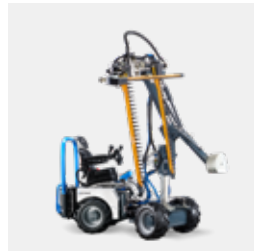
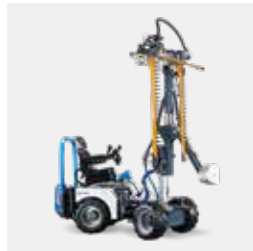
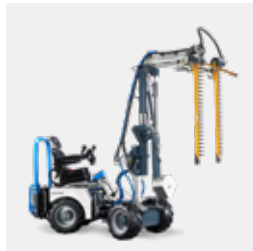
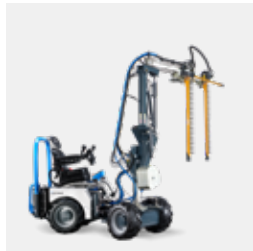
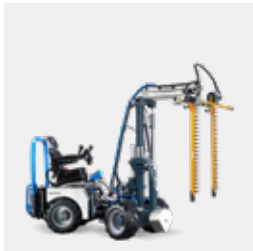

## Accessory

# Transportation platform

Infinitely adjustable, hydraulic tilt.



## Technical data

Width	adjustable from 700 mm to 1,100 mm / adjustable from 27.5 in to 43.5 in
Length	adjustable from 1,050 mm to 1,250 mm / adjustable from 41.5 in to 49 in
Panel height	150 mm / 6 in
Optional	Hydraulic tilt
Weight	110 kg / 243 lbs



---

# Configuration



Transportation platform  
*(adjustable in length & width)*



Frame with manual tilt function



Frame with hydraulic tilt function



Parking jacks



## Accessory

# Dumper skip DPK 540

The dumper skip transports bulk materials, leaves, or other items. For easy unloading, it can be hydraulically tilted.



## Technical data

Width	800 mm / 31.5 in
Length	1,100 mm / 43.5 in
Panel height	760 mm / 2.5 ft
Capacity	530 l / 140 gal
Weight	172 kg / 379 lbs



---

# Configuration



Dumper skip



Frame with hydraulic tilt function



Parking jacks



# On the tool carrier (1)



Sprayer SP 200-60Q



Sprayer HSQ 200-60



Implement mast



Transportation platform



Dumper skip DPK 540



# Rear mounting area (2)

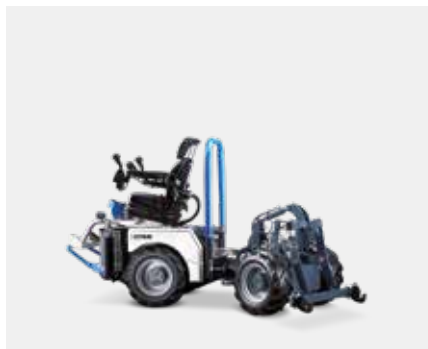

Linkage

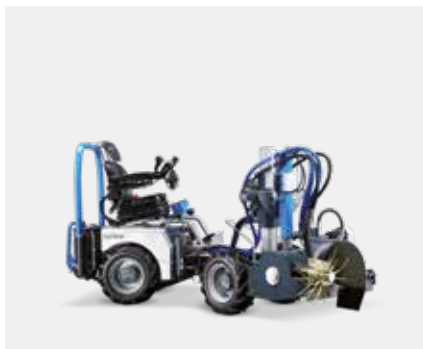

Flail mower SM



Trimmer LSU



Loader bucket

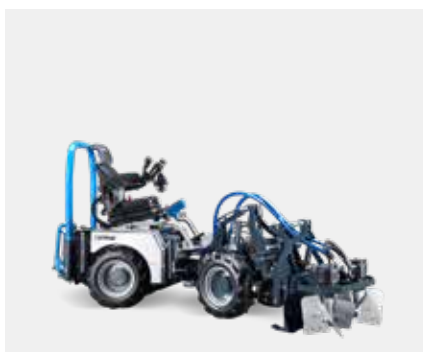

Rotary plough





# COMPANY

Young, dynamic, and innovative:  
At WM technics, progress is our  
top priority – both for us and for  
our customers.

Since 1986, WM technics has been developing and manufacturing **high-quality machinery** for agriculture, urban applications, and ice resurfacing. Our innovative models stand out with advanced technology, ease of use, certified safety concepts, and modern design.

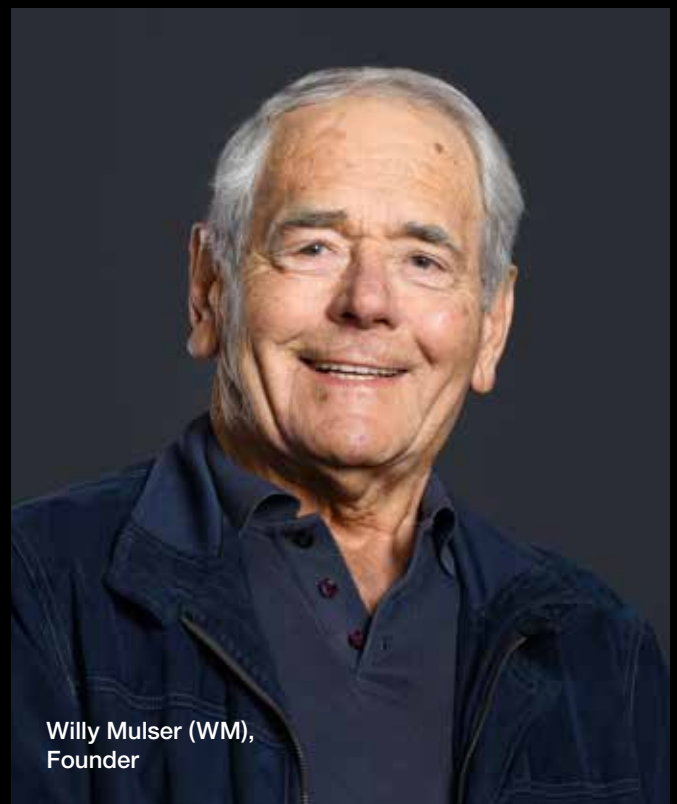
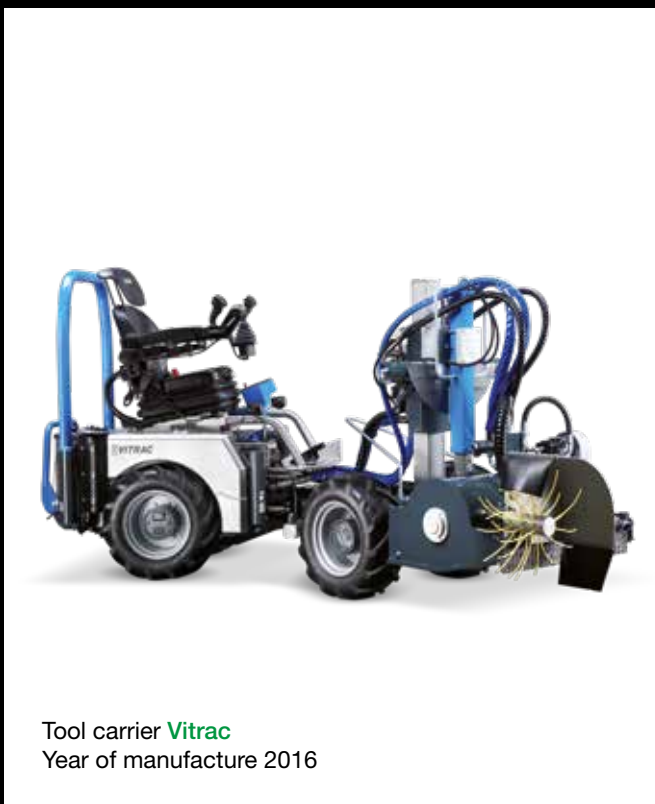

## What we offer

From the narrowest vine rows to the most rugged terrain, WM technics provides the ideal solution for any challenge you face. Our unwavering commitment to product excellence is setting new industry benchmarks, making us a top player on the global stage. Powered

by advanced digital know-how, our design, parts production, and machine assembly are all conducted at our plant in South Tyrol, Italy – guaranteeing absolute premium quality. Bespoke solutions, reduced maintenance needs, and reliable support make WM technics your strong, customer-centric ally.



Markus  
Developer

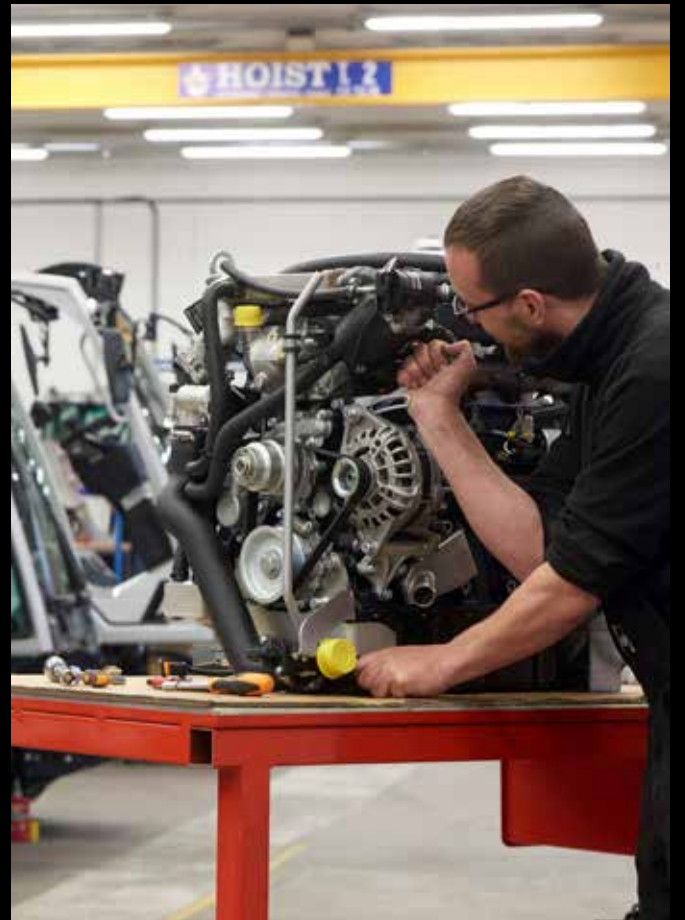
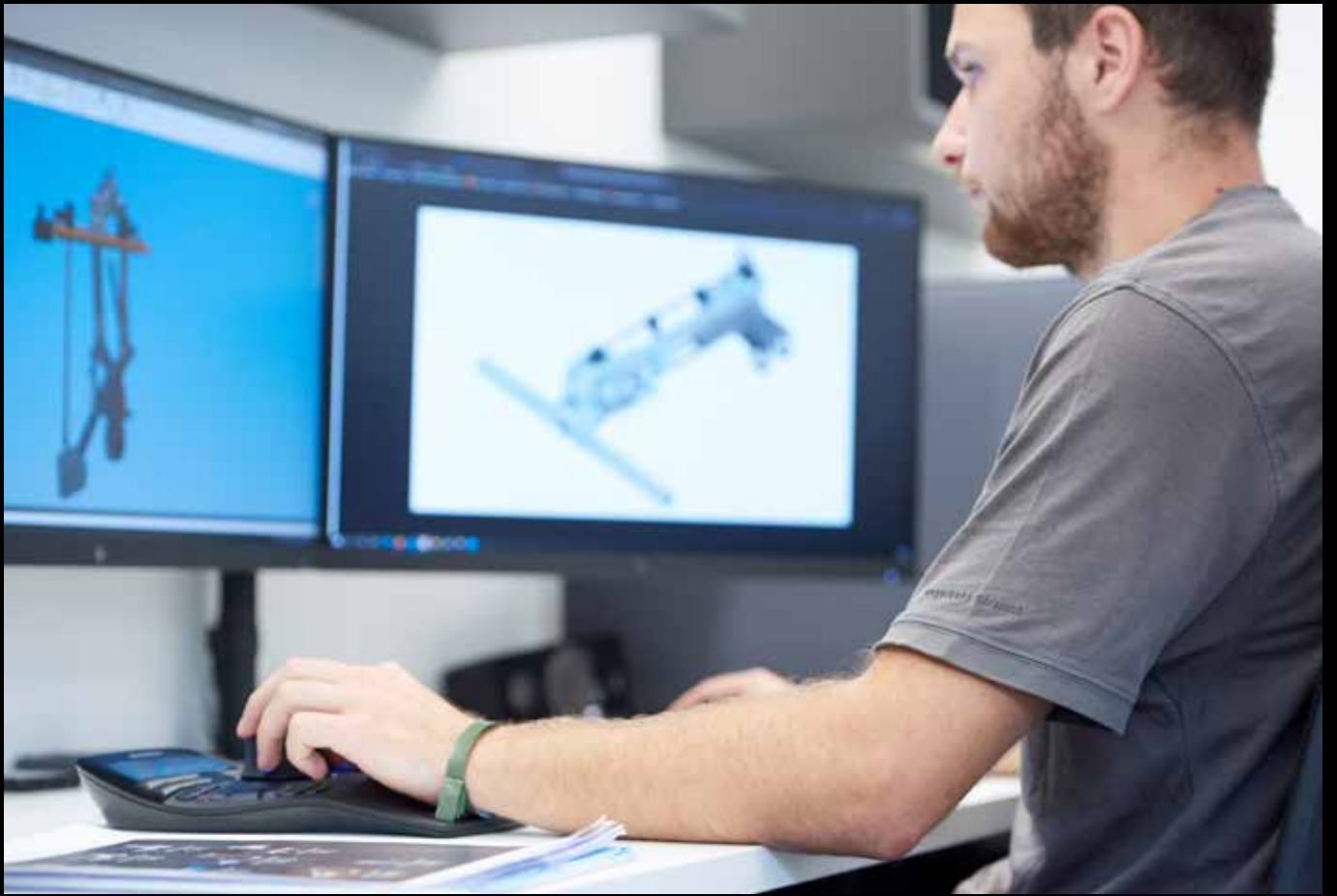



## Advanced innovative power

We approach research and experimentation with meticulous care, always prioritizing networking. Our employees' competence and decades of experience in development, production, and assembly come together in perfect synergy.



## Certified safety

Our top priority is safety and health in the workplace; that's why our tool carriers are designed and built to be user-friendly, based on a solid safety concept.



## Focus & user centricity

With self-motivation at our core, we independently design tool carriers for agricultural and urban use. Our approach remains customer-centric and with a constant focus on the complete value chain.



## Precise production

Every turning and milling component is produced with utmost precision in our facility. We procure standard parts solely from renowned suppliers. Never forgetting about its function and each little detail, each component is carefully crafted.



## Efficient assembly

Thanks to tightly organized processes, WM technics manufactures tool carriers in record time. Every step is documented in detail and maintained with transparency. The assembly is performed with precision and accountability, reducing regular as well as unexpected maintenance needs.



## It's all about quality

WM technics represents innovative tool carriers that redefine standards in efficiency, reliability, and ease of use. Serial production and in-house manufacturing guarantee seamless oversight of all manufacturing processes and components.



## Future-focused sustainability

Our tool carriers are built to last: Starting from the initial sketch, we prioritize the durability of our machines and consistently keep an eye on maintenance and operating expenses. Energy efficiency, low consumption, and optimal profitability converge with the highest performance.



## Service driven by dedication

As our machines are dedicated to meeting your professional needs, we nurture our relationship with customers—before, during, and after the purchase. Your specific requirements are integrated into the manufacturing process to provide tailored solutions.

At WM technics, we strive for excellence in everything we do. Our machines, led by Vitrac, are the result of high-quality components and thoroughly thought-out designs. Developed, manufactured, and assembled in our facilities, we ensure the highest quality, timely deliveries, and low maintenance costs throughout their lifecycle. From individual components to the final product, every step is carefully monitored to deliver **your tool carrier of the future.**

### Ease of use



Using premium components and a well-thought-out design minimizes the need for service work.

### Quality guarantee



Vitrac is a product designed, produced, and assembled within our facility. So we can ensure that we provide the best quality and on-time delivery.

### The right replacement part at any time



On our online portal, replacement parts can be easily and conveniently ordered. You can find the desired part with just one click using the serial number and finding its digital image.

### Series production



Every machine manufactured by WM technics is built in series. We keep track of the components used in each batch and can supply the appropriate spare parts whenever necessary. At the same time, different optional features can be easily added even years later.

### Service & support



Our extensive international team of technicians is constantly up-to-date and will gladly assist you whenever needed.

### Expertise & competence



Each step is meticulously traceable, from producing individual components to the final quality check. All team members are well-trained in their specialized roles and perform their tasks with great care. The advantage for our customers: You receive a technically sophisticated product manufactured to the highest quality expectations.



# PRODUCTS



WM technics represents carefully engineered technology, precision in development, and solutions shaped around real user needs. Every machine is designed with technical rigor, a strong commitment to quality, and a drive for innovation – delivering dependable performance over the long term.

# New Vitrac

Diesel engine with 120 Nm of torque, increased tractive force and a top speed of up to 12 km/h: Vitrac delivers maximum power, control and efficiency for professional viticulture. You can operate even complex and demanding implements without sacrificing comfort, handling or manoeuvrability. The extended wheelbase provides noticeably greater stability and traction, while the optimized steering system with steering wheel performs reliably even in the tightest conditions. A ROPS-certified roll-over protection structure and ergonomically arranged controls ensure safety and working comfort in terraced vineyards, on extreme steep slopes and in narrow passages.



---

 <b>Weight</b>	Basic machine 875 kg / 1,929 lbs
 <b>Performance</b>	18.9 kW (25.7 hp) / 120 Nm at 1,400 rpm
 <b>Steering</b>	± 82°

---



# Viroc Urban

With Viroc, a new era of multifunctional tool carriers for urban applications begins. You benefit from a versatile machine designed to handle a wide range of tasks with ease—from street cleaning and snow removal to the maintenance of parks and green spaces.

Its innovative design concept spans from the advanced, ergonomic cabin to a flexible system for connecting multiple implements, all the way to a chassis engineered for smooth operation on challenging terrain and in urban environments alike. The multifunction joystick ensures intuitive, comfortable, and precise control at all times.



---

 <b>Weight</b>	Basic machine 1,270 kg / 2,800 lbs
 <b>Performance</b>	55.4 kW (75 hp)
 <b>Steering</b>	± 82°

---



# Viroc

Viroc is a highly advanced, multifunctional specialist tractor with a clear focus on the operator and their safety.

It represents a new approach to agricultural work by combining technological innovation with expertise rooted in one of Europe's most traditional wine-growing regions, shaped by the innovative spirit of WM technics.

Developed specifically for viticulture, Viroc performs reliably on steep slopes and in confined crop environments. These characteristics have also made it suitable for use in other agricultural sectors.







 Weight	Basic machine 1,270 kg / 2,800 lbs
 Performance	55.4 kW (75 hp)
 Steering	± 82°

# Mammoth

Developed specifically for use in stadiums and on large ice surfaces of up to 2,600 m<sup>2</sup>, this autonomous machine combines performance with efficiency.

Maintenance-free AC motors, generously sized snow and water tanks, and a quick blade-change system ensure short resurfacing times and smooth daily operation. Thanks to its compact design and the ice edger integrated directly into the frame, the machine also delivers outstanding stability and exceptional maneuverability—even on large rinks.



 Snow tank volume	3 m <sup>3</sup> / compacted 3.6 m <sup>3</sup> 106 ft <sup>3</sup> / compacted 127 ft <sup>3</sup>
 Water tank volume	1,000 l / 1,350 l / 1,750 l 264 gal / 356 gal / 462 gal + snow tank-water tank connection 2,000 l / 2,350 l / 2,750 l 528 gal / 620 gal / 726 gal
 Blade width	2,100 mm / 2,300 mm / 2,500 mm 82 5/8 in / 90 1/2 in / 98 1/2 in Blade change < 60 seconds
 Fields of operation	Pro / Ice stadiums





WM technics GmbH

Plant 1, Headquarters  
Breiener Straße 15  
I-39053 Blumau  
T. +39 0471 353 332  
info@wm-technics.com  
wm-technics.com

Plant 2  
Giuseppe-di-Vittorio-Straße 18  
I-39100 Bozen

Follow us on:

YouTube: *WM Vitrac*  
Facebook: *WM agri*  
Instagram: *WM agri*  
LinkedIn: *WM technics*



