

Accessory

Trimmer LSU

The LSU trimmer was developed for narrow spaces and steep terrain. The deep-set, hydraulic-swivel counterweight guarantees high stability in all working conditions.

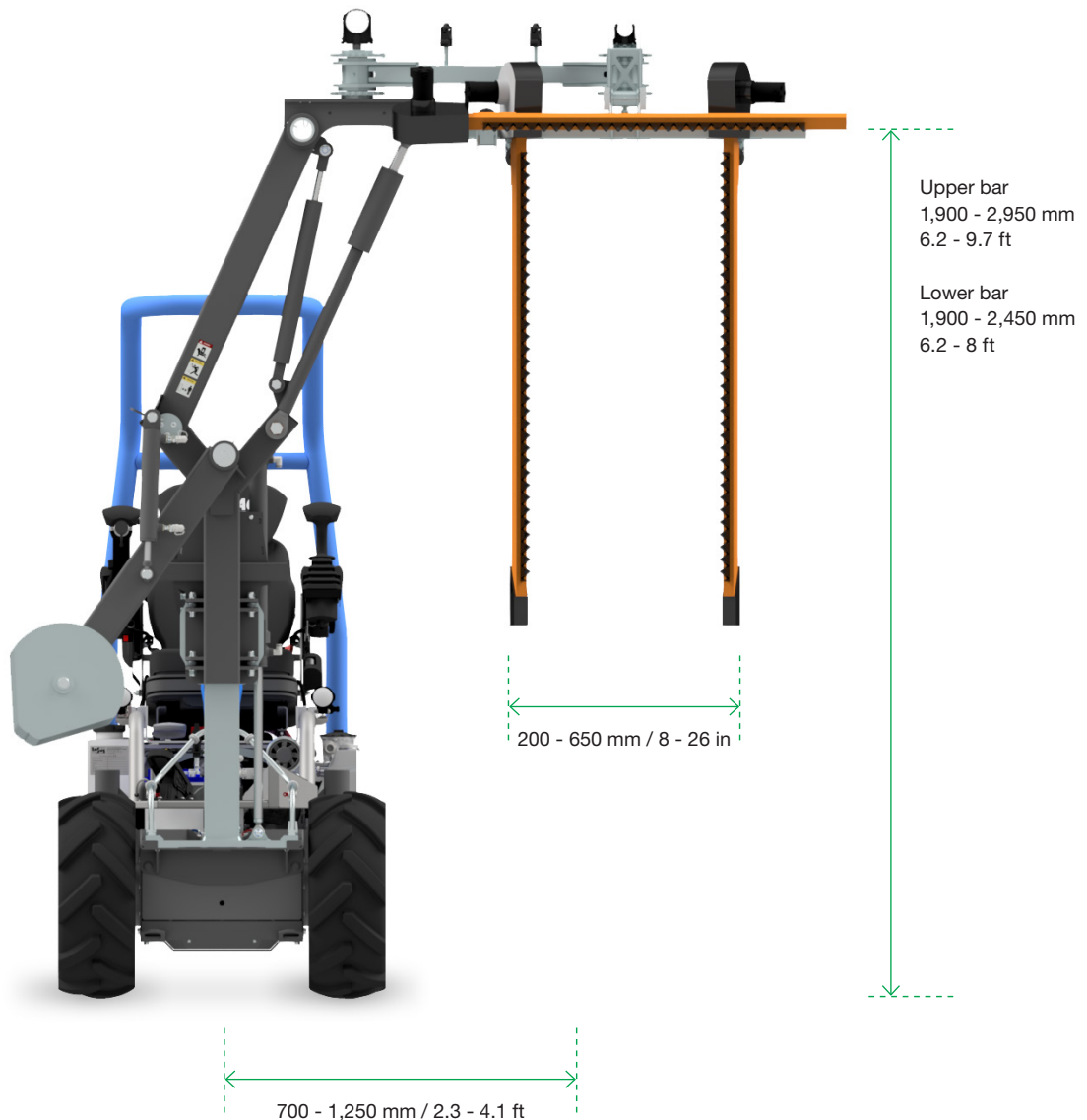

Technical data

Requisite hydraulics for cutter blades	min. 20 l/min at 160 bar / min. 5.5 gal/min at 160 bar
Hydraulic tilt cylinder	7.5 l/min at 130 bar / 2 gal/min at 130 bar
Length of cutter bars	900 - 1,200 mm / 35.5 - 47.5 in
Weight	410 kg incl. counterweight / 900 lbs incl. counterweight