

Accessory

Implement mast

The implement mast sets new benchmarks for multifunctionality in farming. It allows you to mount various accessory units, including the flail mower or trimmer, and position them according to your needs. The implement mast takes your productivity to a new level by offering an all-in-one solution for diverse tasks.

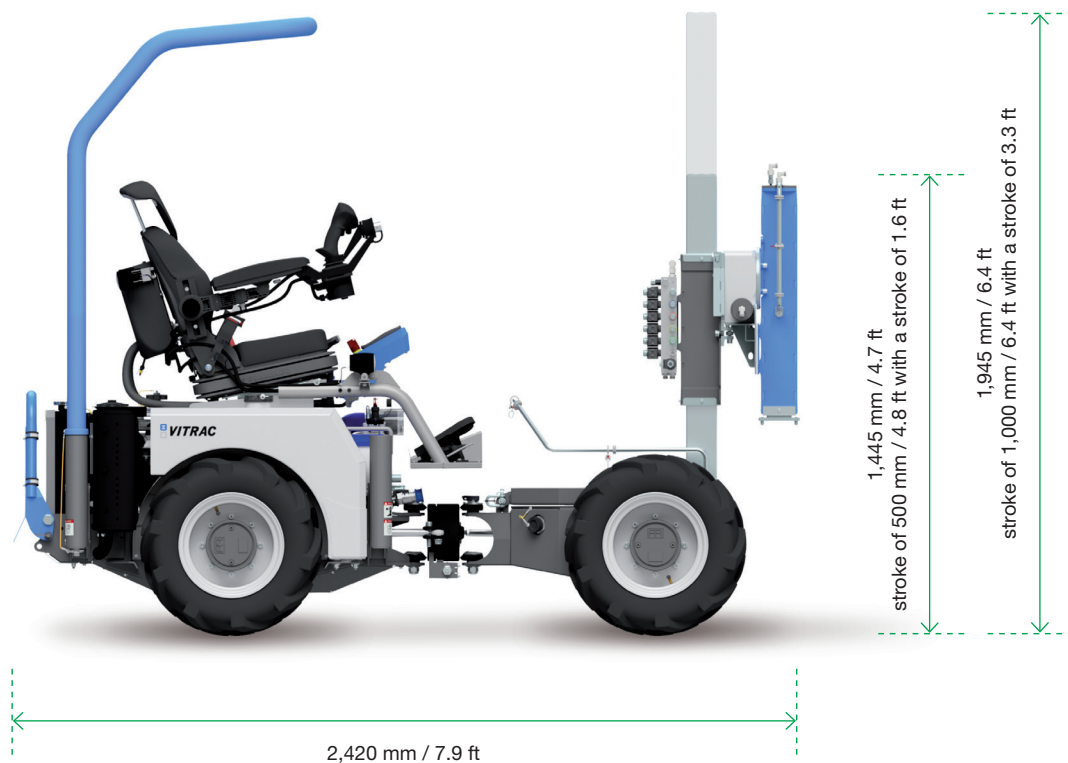

Technical data

Stroke length of the main telescope	500 mm or 1,000 mm / 1.6 ft or 3.3 ft
Tilt angle of the swivel system	$\pm 90^\circ$
Stroke length of the 2 nd telescope	500 mm / 20 in
Weight small mast	170 kg / 375 lbs
Weight high mast	190 kg / 419 lbs

Configuration



Implement mast with hydraulic block unit

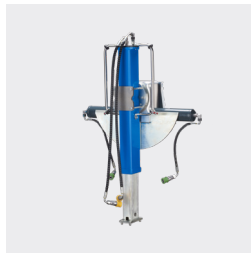

Swivel system with 500 mm telescope



Quick-release system for the telescope



Parking jacks

Available with the flail mower



Mower model SM80 with a working width of 80 cm / 2.6 ft



Mower model SM90 with a working width of 90 cm / 3.0 ft



Hydraulic shoot remover
(on request: individually controllable brush)



Parking jacks

Available with the trimmer



Trimmer LSU with hydraulic functions

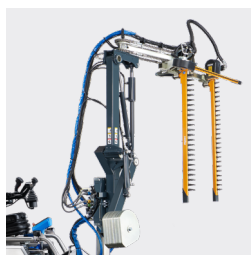

Pellenc cutter bars



Parking jacks

with other manufacturers

